

Absolute Process Instruments, Inc.

Manufacturer of Quality Signal Conditioners Transmitters & Isolators

Application Notes

- General Info
- Temperature
- Pressure
- Flow
- Speed
- Weighing
- Process

Monitoring Critical Heater Operation

PROBLEM

There is a multi-heater mold where constant temperature is critical to the quality of a product. If a single heater in the mold goes down, the operator must know as soon as possible and shut the mold down to prevent scrap.

SOLUTION

The **API 1600 G** AC Input Single Alarm Trip module will accept a mAAC input from a current transformer (CT) and provide a contact closure when the detected current falls below a preset level. For example if the output from the CT is 60 mAAC when all three heaters are on, you would adjust the setpoint for 55 mA. Should one of the heaters fail the total current would fall approximately 20 mA causing an alarm indication and allowing the operator to shut down the system. By using a separate alarm for the upper and lower portions of the mold the troubleshooting time for the repair crew is reduced. Scrap is also reduced by detecting and correcting the problem before a large amount of defective product is produced.

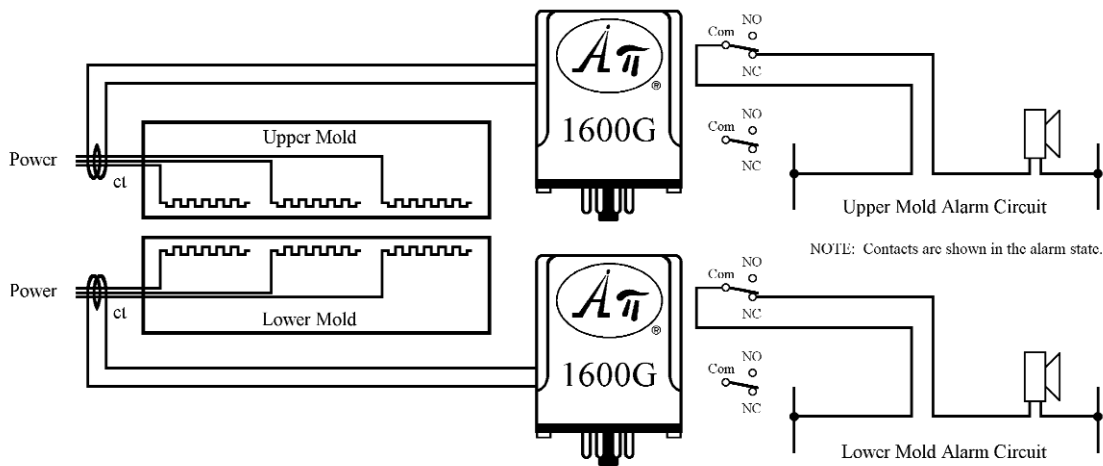

NOTE: During the normal ON/OFF cycle of the temperature controller the low current alarm will cycle with the heater. When the alarm fails to reset as the heaters are turned back on or if an alarm indication occurs during the "heat" cycle one or more of the heaters have failed.

Did You Know...?

The socket which we include with the **API 6010 G 5A** AC to DC Transmitter module has the shunt resistor built-in, allowing the module to be removed without damage to the current transformer.

FREE APPLICATION ASSISTANCE
 Call  **Customer Service**
800-942-0315

