

Description of Controls

1. **Input LED.** This GREEN Light provides a visual indication that a signal is being sensed by the input circuitry of the module. It also indicates the input signal strength by changing in intensity as the process changes from minimum to maximum. Note: If the LED fails to illuminate, or fails to change in intensity as the process changes, this may indicate a problem with module power or Signal Input Wiring.

2. **Test Pushbutton** When held depressed, will generate a continuous Output Signal independent of the Input Signal. When released, the Output will return to normal. This Output is field adjustable from 0 to 100% of the calibrated Output range via the "Test Range Adjustment" pot. This feature can be used as a system diagnostic aid during initial start-up or during troubleshooting

EXAMPLE: If you are using a 4-20 mA current loop, when the pushbutton is held depressed, the output from the Isolator will be a constant signal between 4 and 20 mA depending on the setting of the Test Range Adjustment pot. This will drive the device on the Output side of the loop (a panel meter, chart recorder, etc.) with a known good signal. This has divided your entire system in half making it easier to troubleshoot.

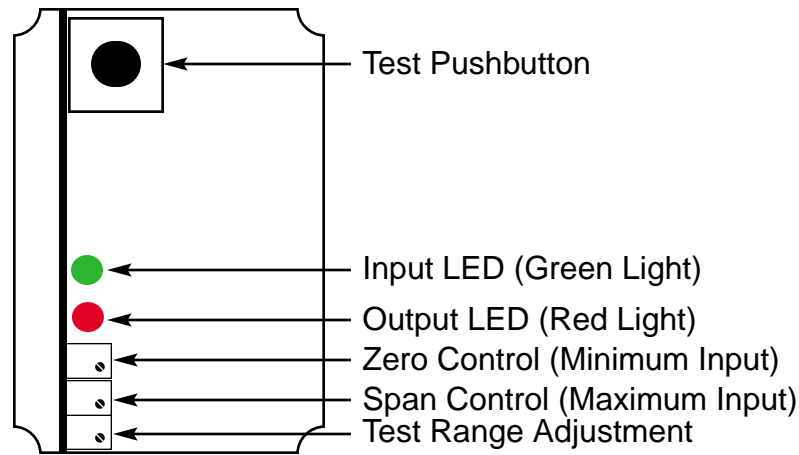

Figure 2

API 4058G

3. **Test Range Adjust** Turning this Multi-turn Potentiometer while holding the Test Pushbutton depressed varies the Output Signal from 0 to 100% of the calibrated Output Range.

4. **Span Control** Allows for fine adjustments of the **Maximum** Output Signal. The Span Control should only be adjusted when the Input Signal is at its maximum potential. This will produce the corresponding maximum Output Signal from your API unit. **Example:** If you desire a 4-20 mA Output Signal, the Span Control will provide adjustment for the 20 mA signal.

5. **Zero Control** Allows for fine adjustments of the **Minimum** Output Signal. The Zero Control should only be adjusted when the Input Signal is at its minimum potential. This will produce the corresponding minimum Output Signal from your API unit. **Example:** If you desire a 4-20 mA Output Signal, the Zero Control will provide adjustment for the 4 mA signal.

6. **Output LED** This RED Light provides a visual indication that a signal is being sensed by the units output circuitry. It also indicates the signal strength by changing in intensity as the input changes from minimum to maximum. **Note:** If a Current Output is selected, the RED LED will only light if the loop current path is complete. For either Current or Voltage Outputs, failure to illuminate or a failure to change in intensity as the process changes may indicate a problem with the module power or Signal Output Wiring. **Example:** If you have selected a 4-20 mA output to go to a chart recorder and you have no indications on the recorder, or if you see no Red LED indication on your API unit, you can suspect an open circuit in the output loop or incorrect wiring.

Ranging Switches

Located on the side of your API unit are four rotary switches and one slide switch which are used to select your desired Input and Output Ranges. There is NEVER a need to open the case. In addition, the module contains Range Tables and Labels designed to assist you in ranging your module.

1. **Output Selector Slide Switch.** This slide switch is the first step in ranging your unit. It allows the operator to select either a Voltage or Current as and Output. **Example:** If a 4-20 mA Output is desired the Output selector is placed in the "I" position. If the operator desires a 0-10 VDC Output, the Output Selector is placed in the "V" position.

2. **Rotary Range Selector Switches.** These switches will provide the selected amount of amplification or attenuation as well as the necessary amount of offset to accomplish the desired range. **Example:** We will set the switches for a 3 mv/v Input signal with 10 VDC Excitation and a 4-20 mA Output. Our desired switch code is "CD5" with the Voltage / Current Selector in the "I" position and the Excitation Switch is set for 10 VDC.

Switch "A" is set in position A. Switch "B" is set to position C. Switch "C" is set to position D. Switch "D" is placed in position 5.

Range Selection Switches

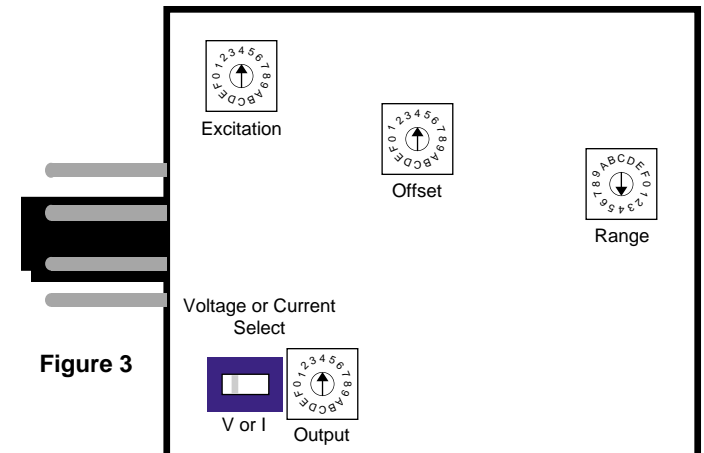

Figure 3

General Information

Strain Gauges and Load Cells are normally passive devices that are commonly referred to as "bridges" due to the four-resistor Wheatstone bridge configuration used in their design. These sensors require a precise excitation source to produce an output that is directly proportional to the load, pressure, etc. that is applied to the sensor. The exact output (measured in millivolts) is determined by the sensitivity of the sensor (mV/V) and the excitation voltage applied. For example, a load cell rated for 3mV/V sensitivity and 10VDC excitation will produce an output of 0 to 30mV for load variations from 0 to 100%.

The API 4058 G consists of four(4) rotary switches and one(1) slide switch which must be configured to match the specifications of the input sensor(s) and the output requirements. The API 4058 G provides the excitation voltage to the sensors and receives the resulting millivolt signal in return.

To determine the overall millivolt input required by the API 4058G, examine your sensor for the specified Excitation Voltage and the millivolt per volt rating. Multiply the Excitation Voltage by the millivolt per volt value, this will give the overall millivolt input required by the API 4058G.

Example: 2 mV/V x 10 Volt Excitation = 20mV Input to the API 4058G.

General Calibration

The first step in calibrating the API 4058G is to determine the correct Excitation Voltage needed for your sensor and rotate switch "A" to the appropriate position. The Excitation Fine Adjustment may be used to "trim" this voltage.

After determining the overall millivolt Input, refer to the Ranging Tables located on the unit, and set the Ranging Switches (refer to figure 3) to achieve the desired Input and Output combination.

With the **Minimum** signal from your sensor representing zero, adjust the "**Zero Control**" (refer to figure 2) for the desired minimum Output signal.

With the **Maximum** signal from your sensor representing full scale, adjust the "**Span Control**" (refer to figure 2) for the desired maximum Output signal.

Note: This procedure may have to be repeated several times to achieve the desired accuracy over the selected range. This is a basic calibration procedure and does not account for offsets or tare weights. To achieve optimum results, it is recommended that the API 4058G be calibrated by an accurate "Bridge" simulator before being placed in service.

CAUTION: Care must be taken to prevent the Excitation leads from shorting together. This will cause internal damage to the API 4058G

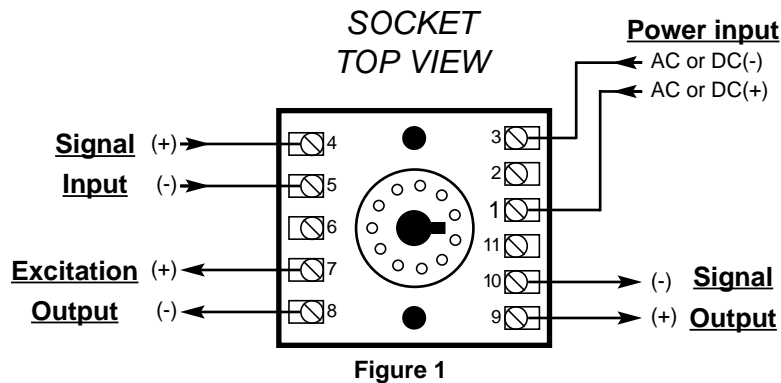

Figure 1

Electrical Connection

All of us at Absolute Process Instruments place the highest importance on Electrical Safety. To ensure the safety of our customers and their satisfaction with our products, we suggest that all wiring be performed by qualified personnel only. The Electrical Connections are referenced to an Industry standard 8-pin octal socket.

Power Input Terminals. Terminals 1 and 3 are wired with the desired AC or DC Power. The white label on the side of your API unit will have the power requirements listed as specified on your purchase order. If your API unit is configured with a 12 or 24 VDC power supply, care must be taken when applying power. Polarity **MUST** be observed when using a DC supply. The positive (+) is applied to terminal 1 and, the negative (-) is applied to terminal 3.

Signal Input Terminals. Terminals 4 and 5 provide connections for the appropriate Input Signal. Polarity must be observed when connecting the Signal Input. The Positive connection (+) is applied to terminal 4 and the Negative (-) is applied to terminal 5.

Excitation Output Terminals. Terminals 7 and 8 provide connections for the DC Voltage that is used to Excite the Load Cell. Polarity must be observed when connecting the Excitation Output. The Positive connection (+) is applied to terminal 7 and the Negative (-) is applied to terminal 8.

Signal Output Terminals. Terminals 9 and 10 provide connections for the appropriate Output Signal. Polarity must be observed when connecting the Signal Output to the load. The Positive connection (+) is connected to terminal 9 and the Negative (-) is connected to terminal 10. These are the minimum connections required for the API unit to function correctly.

Absolute Process Instruments

1029 Butterfield Rd. Vernon Hills, Illinois 60061

Phone (800) 942-0315 Fax (800) 949-7502

Visit us on the the World Wide Web at [http:// www.api-usa.com](http://www.api-usa.com) E-Mail us at support@api-usa.com