

## Description of Controls

1. **Input LED.** This GREEN Light provides a visual indication that a signal is being sensed by the input circuitry of the module. It also indicates the input signal strength by changing in intensity as the process changes from minimum to maximum. Note: If the LED fails to illuminate, or fails to change in intensity as the process changes, this may indicate a problem with module power or Signal Input Wiring.

2. **Test Pushbutton** When held depressed, will generate a continuous Output Signal independent of the Input Signal. When released, the Output will return to normal. This Output is field adjustable from 0 to 100% of the calibrated Output range via the "Test Range Adjustment" pot. This feature can be used as a system diagnostic aid during initial start-up or during troubleshooting

**EXAMPLE:** If you are isolating a 4-20 mA current loop, when the pushbutton is held depressed, the output from the Isolator will be a constant signal between 4 and 20 mA depending on the setting of the Test Range Adjustment pot. This will drive the device on the Output side of the loop (a panel meter, chart recorder, etc.) with a known good signal. This has divided your entire system in half making it easier to troubleshoot.

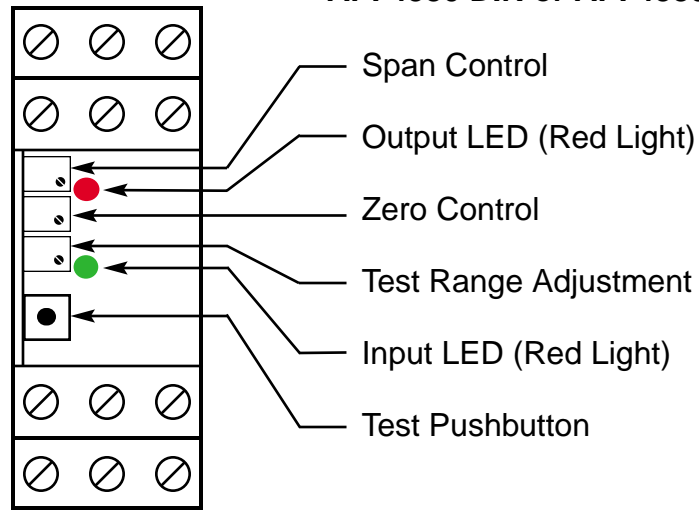

Figure 3

3. **Test Range Adjust** Turning this Multi-turn Potentiometer while holding the Test Pushbutton depressed varies the Output Signal from 0 to 100% of the calibrated Output Range.

4. **Span Control** Allows for fine adjustments of the **Maximum** Output Signal. The Span Control should only be adjusted when the Input Signal is at its maximum potential. This will produce the corresponding maximum Output Signal from your API unit. **Example:** If you desire a 4-20 mA Output Signal, the Span Control will provide adjustment for the 20 mA signal.

5. **Zero Control** Allows for fine adjustments of the **Minimum** Output Signal. The Zero Control should only be adjusted when the Input Signal is at its minimum potential. This will produce the corresponding minimum Output Signal from your API unit. **Example:** If you desire a 4-20 mA Output Signal, the Zero Control will provide adjustment for the 4 mA signal.

6. **Output LED** This RED Light provides a visual indication that a signal is being sensed by the units output circuitry. It also indicates the signal strength by changing in intensity as the input changes from minimum to maximum. **Note:** If a Current Output is selected, the RED LED will only light if the loop current path is complete. For either Current or Voltage Outputs, failure to illuminate or a failure to change in intensity as the process changes may indicate a problem with the module power or Signal Output Wiring. **Example:** If you have selected a 4-20 mA output to go to a chart recorder and you have no indications on the recorder, or if you see no Red LED indication on your API unit, you can suspect an open circuit in the output loop or incorrect wiring.

## Ranging Switches

Located on the side of your API unit are three rotary switches and two slide switches which are used to select your desired Input and Output Ranges. There is NEVER a need to open the case. In addition, the module contains Range Tables and Labels designed to assist you in ranging your module.

1. **Input and Output Selector Slide Switches.** These two slide switches are the first step in ranging your unit. They allow the operator to select either Voltage or Current Inputs and Outputs. **Example:** If a 4-20 mA input and output are desired, both the Input selector and Output selector are placed in the "I" position. If a Voltage Input or Output were needed the switches would be placed in the "V" position.

2. **Rotary Range Selector Switches** These switches will provide the selected amount of amplification or attenuation as well as the necessary amount of offset to accomplish the desired range. **Example:** We will set the switches for a 0-10 VDC input and a 4-20 mA output. Set the Input selector slide switch to the "V" position. Place the output selector slide switch to the "I" position. Locate the desired range from the chart on the side of the unit. Our desired switch code is "563". Now rotate switch A to the 5 position, switch B to the 6 position and switch C to the 3 position. The ranging process is now complete and, the unit is ready for final Calibration and Installation.

## API 4380 DIN or API 4380 DD

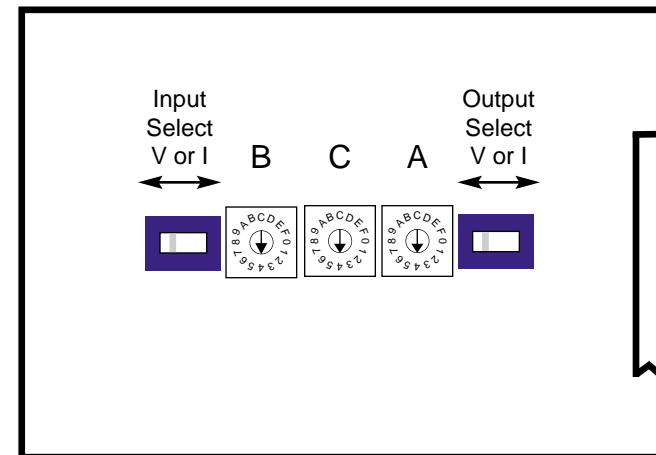

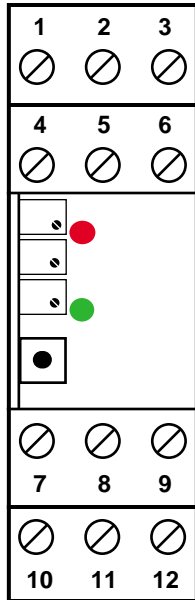

API 4380 DIN

## Electrical Connections

All of us at Absolute Process Instruments place the highest importance on Electrical Safety. To ensure the safety of our customers and their satisfaction with our products, we suggest that all wiring be performed by qualified personnel only. The Electrical Connections are provided via Screw Down Terminals located on the unit.

**Power Input Terminals.** Terminals **10** and **12** are wired with the desired AC or DC Power. The API 4380 DIN will operate with AC Voltages from 80 to 265 Volts and DC Voltages from 48 to 300 Volts. If you are using the Low Voltage API 4380 DD unit, it can accommodate voltages from 9 to 30 Volts DC, however, polarity **MUST** be observed when using a DC supply. The positive (+) is applied to terminal 12 and, the negative (-) is applied to terminal 10.

**Signal Input Terminals.** Terminals **7** and **8** provide connections for the appropriate Input Signal. Polarity must be observed when connecting the Signal Input. The Positive connection (+) is applied to terminal 8 and the Negative (-) is applied to terminal 7.

**Signal Output Terminals.** Terminals **1** and **2** provide connections for the appropriate Output Signal. Polarity must be observed when connecting the Signal Output to the load. The Positive connection (+) is connected to terminal 2 and the Negative (-) is connected to terminal 1. These are the minimum connections required for the API unit to function correctly.

### How To Utilize The +12 VDC Loop Excitation Source

**Note:** If a Passive Device is not being utilized, Terminal 9 requires no connection.

As an added standard feature, this module contains a 12 Volt DC Supply that can be used to power a passive Input device such as a Speed Sensor, Proximity Switch, etc. Following will be an example of a "typical" application; however, since many devices exist, it is very important you consult the manufacturer of your specific sensor to determine it's compatibility.

**Example:** In this application, a Speed Sensor requiring external power to generate an output is used in conjunction with an API module to optimize a process. By utilizing the 12 Volt Loop Excitation Source of the API module, an additional external power supply may be eliminated resulting in a reduction to your system cost and wiring. The Speed Sensor shown in Fig. 2 requires two connections. The first (typically labeled Positive(+) or Power) should be wired to Terminal 9 of the unit. The second (typically labeled Negative(-) or Signal) should be wired to Terminal 8 of the unit. No connection to Terminal 7 is necessary.

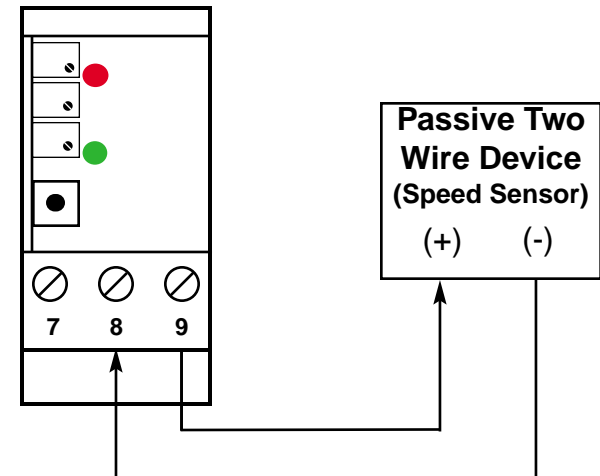

Figure 2

## Absolute Process Instruments

Phone (800) 942-0315 Fax (800) 949-7502

Visit us on the the World Wide Web at [http:// www.api-usa.com](http://www.api-usa.com) E-Mail us at [support @api-usa.com](mailto:support@api-usa.com)