

AC Input Alarm Trips

API 1600 G, API 1620 G



Input: 0-50 mVAC to 0-300 VAC, 0-1 mAAC to 0-900 mAAC

Outputs: One DPDT Relay or Two SPDT Relays

- Precision Internal AC/DC Converter
- Field Adjustable Setpoints
- High Capacity 7 Amp Relay Contacts
- Input LoopTracker® & Alarm Status LEDs
- Alarm Test/Reset Pushbutton

Applications

- Process Limit Backup Alarm
- Over, Under, Out-of-Range Voltage/Current
- Heater Break, Conveyor Jam Alarm

Specifications

Input Range

Factory Configured—Please specify input range

	Minimum	Maximum
Voltage:	0-50 mVAC	0-300 VAC
Current:	0-1 mAAC	0-900 mAAC

System voltages must not exceed socket voltage rating

5A Current shunt available for input ranges up to 5 amps

Consult factory if higher input range is required

Input Impedance (Voltage)

200 kΩ minimum

Input Voltage Burden (Current)

1.0 V_{RMS} maximum

Input Protection, Common Mode

750 VDC or 750 VAC_p

LoopTracker

Variable brightness LED indicates input level and status

Relay Output

Factory Configured—See Options for other relay configurations

API 1600 G One DPDT contact set
 HI alarm, normal action, non-latching standard
 7 A @ 240 VAC maximum resistive load
 3.5 A @ 240 VAC maximum inductive load
 8 A @ 30 VDC maximum

API 1620 G Two SPDT contacts
 HI/LO, normal action, non-latching standard
 7 A @ 240 VAC maximum resistive load
 3.5 A @ 240 VAC maximum inductive load
 8 A @ 30 VDC maximum

CAUTION: Socket contacts may limit system rating. External contact protection such as an RC snubber is recommended for inductive loads.

Alarm Setpoint

12 turn potentiometer, field adjustable from 0 to 100% of span

Deadband

API 1600 G 1.0 to 100% of span, 12 turn potentiometer

API 1620 G Fixed at 1% of span, standard

API 1620 G A 1.0 to 100% of span, 1 turn potentiometer

Functional Test/Reset Button

Toggle relay(s) to opposite state when pressed

Resets latching relay on 1600G with HT option

Response Time

70 milliseconds typical

Ambient Temperature Range and Temperature Stability

-10°C to +60°C operating ambient

Better than ±0.02% of span per °C temperature stability

Power

Standard: 115 VAC ±10%, 50/60 Hz, 2.5 W max.

P option: 80-265 VAC or 48-300 VDC, 50/60 Hz, 2.5 W typical

A230 option: 230 VAC ±10%, 50/60 Hz, 2.5 W max.

D option: 9-30 VDC, 2.5 W typical

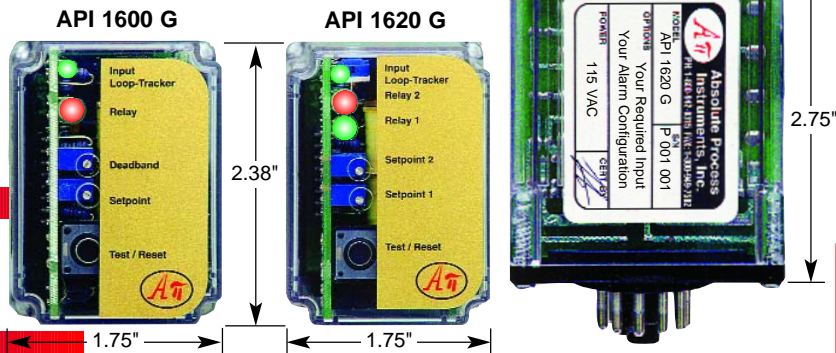

Description and Features

The **API 1600 G** and **API 1620 G** are factory configured for either an AC voltage or current input and provide alarm contact outputs. Heavy-duty relay contacts allow the module to directly control high capacity loads.

API exclusive features include a **LoopTracker** LED that varies in intensity with changes in the process signal, alarm status LEDs for each alarm, and a **Functional Test Pushbutton** to toggle the relays independent of the input.

The **API 1600 G** provides a single setpoint adjustment and DPDT relay contacts. The alarm output can be factory configured for HI or LO operation, non-latching or latching, normal or reverse acting.

The **API 1620 G** contains two independent setpoints with two SPDT relay contact outputs. The alarm output can be factory configured for HI/HI, HI/LO, LO/HI or LO/LO operation, normal acting or reverse acting.

Models & Options

Factory Configured—Please specify input range and options

API 1600 G AC input, DPDT HI alarm, normal action, non-latching, 115 VAC

API 1600 G5A Up to 5 amp AC input with socket and 25 W shunt, DPDT, HI alarm, normal action, non-latching, 115 VAC

API 1620 G AC input, 2 SPDT, HI/LO, normal action, non-latching, 115 VAC

API 1620 G5A Up to 5 amp AC input with socket and 25 W shunt, 2 SPDT relays, HI/LO, normal action, non-latching, 115 VAC

Options—Add to end of model number

P	Powered by 80-265 VAC or 48-300 VDC, 50/60 Hz
A230	Powered by 230 VAC, 50/60 Hz
D	Powered by 9-30 VDC
R	Reverse-acting alarms
L	Low trip (on decreasing signal) for 1600 G
HT	Latching alarm with pushbutton reset, API 1600 G only
HP	Latching alarm with power-off reset, API 1600 G only
A	Adjustable deadbands for 1620 G
HH	High/High trip for 1620 G instead of High/Low
LL	Low/Low trip for 1620 G instead of High/Low
U	Conformal coating for moisture resistance

Accessories—Order as a separate line item

API 011 11-pin socket

API 011 FS 11-pin finger safe socket

API TK36 DIN rail, 35 mm W x 39" L, aluminum

See Page 58 for Current Transformers



ELECTRICAL CONNECTIONS

WARNING! All wiring must be performed by qualified personnel only. This module requires an industry-standard 11-pin socket. Order API 011 or finger-safe API 011 FS socket separately. Socket voltage rating must be observed!

Power Input Terminals – The white label on the side of the API module will indicate the power requirements. AC power is connected to terminals 1 and 3. For DC powered modules, polarity **MUST** be observed. Positive (+) is wired to terminal 1 and negative (-) is wired to terminal 3.

Signal Input – Terminals 4 and 5 are used for the AC input.

AC Input

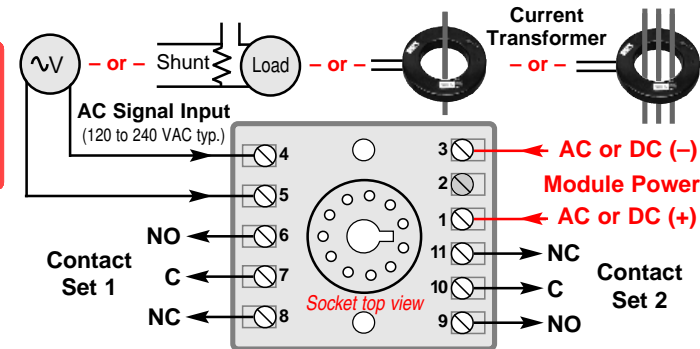

Relay Output Terminals – Terminals 6, 7, 8 and 9, 10, 11 provide the appropriate connections for the desired relay operations. (NO = Normally Open, NC = Normally Closed, C = Common). NOTE: Although the API 1600 G has a pair of relays, these relays will energize and de-energize in unison. The API 1620 G will accommodate independent relay operations.

SETUP

The input range and alarm types are pre-configured at the factory as specified on your order. No input calibration is necessary. Contact factory for custom ranges or modifications.

Setpoint Control – This multi-turn potentiometer (one for each setpoint on the API 1620 G) allows the operator to adjust the level at which the alarm is activated. This control is adjustable from 0 to 100% of the input range.

Deadband Control – The API 1600 G deadband potentiometer allows the alarm trip and reset window to be adjusted symmetrically about the setpoint from 1 to 100% of the span.

The deadband is fixed at 1% of span on the API 1620 G. The API 1620 G A with adjustable deadband option allows deadbands to be adjusted symmetrically about each setpoint from 1 to 100% of the span.

Adjustable deadband allows the operator to fine tune the point at which the alarm trips (alarm condition) and resets (non alarm condition). The deadband is typically used to prevent chattering of the relays or false trips when the process signal is unstable or changes rapidly.

API 1620 G Alarm Configuration – The alarm configuration of the API 1620 G is pre-configured at the factory per your order, but if a change is necessary, internal jumpers can be used to modify the alarm type as follows.

1. Unplug the module from the socket.
2. Remove the 4 screws from the module bottom and remove the plastic case.
3. Unplug the circuit board with the test button from the base.
4. Note location of jumper block at top left of circuit board next to test button.
5. Place jumpers as indicated for desired alarm operation. The standard HI/LO setting is with one jumper across the two top pins or with no jumper at all. Never place a jumper across the two bottom pins!
6. Replace board, cover, and screws.

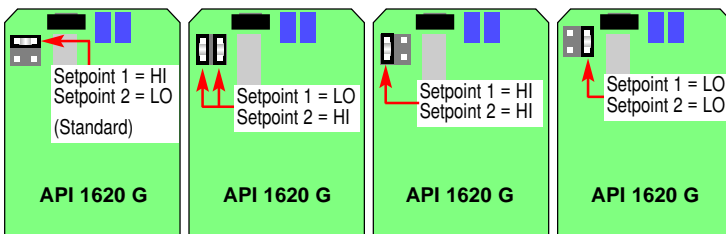

TEST BUTTON

The functional test pushbutton toggles the alarm status independent of the input when depressed. It verifies the alarm and system operation and also provides the additional function of unlatching the alarm on the **API 1600 G HT** with the latching alarm option.

OPERATION

GREEN LoopTracker® Input LED – Provides a visual indication that a signal is being sensed by the input circuitry of the module. It also indicates the input signal strength by changing in intensity as the process changes from minimum to maximum to provide a quick visual picture of your process loop at all times. If the LED fails to illuminate, or fails to change in intensity as the process changes, this may indicate a problem with module power or signal input wiring. This feature greatly aid in saving time during initial start-up or troubleshooting.

Bi-Color Alarm LED – Provides a visual indication of the alarm status. In all configurations, a GREEN LED indicates a non-alarm condition and a RED LED indicates an alarm condition.

Alarm Relays – In the normal mode of operation, the relay coil is energized in a non-alarm condition and de-energized in an alarm condition. This will create an alarm condition if the module loses power. For a normal acting, non-latching configuration, the alarm will activate when the input signal exceeds the setpoint (HI alarm) or falls below the setpoint (LO alarm), then will automatically reset when the alarm condition no longer exists.

If reverse acting mode is selected, the relay coil is de-energized in a non-alarm condition and energized in an alarm condition. The alarm will activate when the input signal exceeds the setpoint (HI alarm) or falls below the setpoint (LO alarm), then will automatically reset when the alarm condition no longer exists.

API 1600 G HT Latching Alarm – For units with the **HT** latching alarm option, the Test Switch is also used to reset the alarm relays. The alarm relay contacts will remain in the alarmed condition until the input signal falls below the high alarm setpoint (or above low alarm setpoint, depending on configuration) and the Test/Reset pushbutton has been pressed or power to the unit has been switched off.

API 1600 G HP Latching Alarm – For units with the **HP** latching alarm option, the alarm relay contacts will remain in the alarmed condition until the input signal falls below the high alarm setpoint (or above low alarm setpoint, depending on configuration) and the power to the unit has been switched off.

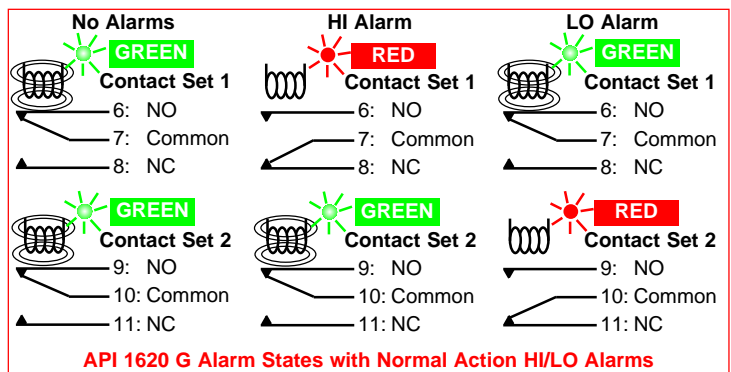
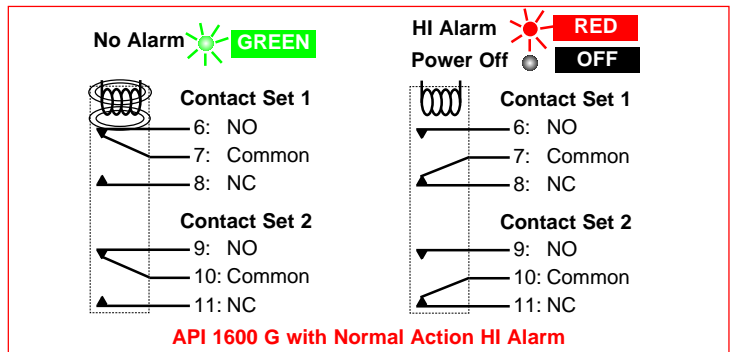

API maintains a constant effort to upgrade and improve its products. Specifications are subject to change without notice. Consult factory for your specific requirements.