

# Thermocouple to DC Transmitter, Isolated & Linearized API 4130 G L



**Input:** J, K, T, E, R or S Thermocouples  
**Output:** 0-1 V to  $\pm 10$  VDC or 0-1 mA to 4-20 mA

- Wide Range of Thermocouple Types
- Automatic Cold Junction Compensation
- Voltage or Current Output
- Input and Output LoopTracker® LEDs
- Functional Test Pushbutton

## Applications

- Isolate and Transmit T/C Signals
- Rescale T/C Temperature Range to Full 4-20 mA

## Specifications

### Thermocouple Types

Factory Configured—Please specify T/C type and temperature range

Thermocouple type: J, K, T, E, R, or S

Temperature range: °F or °C

Minimum recommended span is 5 mV

Consult factory for other T/C types

### Cold-Junction Compensation

Automatic for specified thermocouple

### T/C Burn-out Protection

Upscale burnout standard

Downscale burnout optional, specify option **B** on order

### T/C Current

Less than 1.0  $\mu$ A including burnout sense

### LoopTracker

Variable brightness LEDs indicate input/output loop level and status

### Output Range

Factory Configured—Please specify output range

	Minimum	Maximum
Voltage (10 mA max.):	0-1 VDC	0-10 VDC
Bipolar Voltage ( $\pm 10$ mA max.):	$\pm 1$ VDC	$\pm 10$ VDC
Current (12 V compliance):	0-1 mADC	0-20 mADC

Consult factory for special ranges

### Output Linearity

Linearized to better than  $\pm 0.5\%$  of span

Optional linearization to  $\pm 0.2\%$  of span (call factory)

### Output Zero and Span

Multiturn potentiometers to compensate for load and lead variations  
 $\pm 15\%$  of span adjustment range typical

### Functional Test Button

Sets output to test level when pressed

Factory set to approximately 50% of span

### Response Time

70 milliseconds typical

### Isolation

2000  $V_{RMS}$  minimum, full isolation; power to input, power to output, input to output

### Ambient Temperature Range

$-10^{\circ}\text{C}$  to  $+60^{\circ}\text{C}$  operating

### Temperature Stability

Better than  $\pm 0.04\%$  of span per  $^{\circ}\text{C}$

### Power

Standard:	115 VAC $\pm 10\%$ , 50/60 Hz, 2.5 W max.
<b>P</b> option:	80-265 VAC or 48-300 VDC, 50/60 Hz
<b>A230</b> option:	230 VAC $\pm 10\%$ , 50/60 Hz, 2.5 W max.
<b>D</b> option:	9-30 VDC, 2.5 W typical

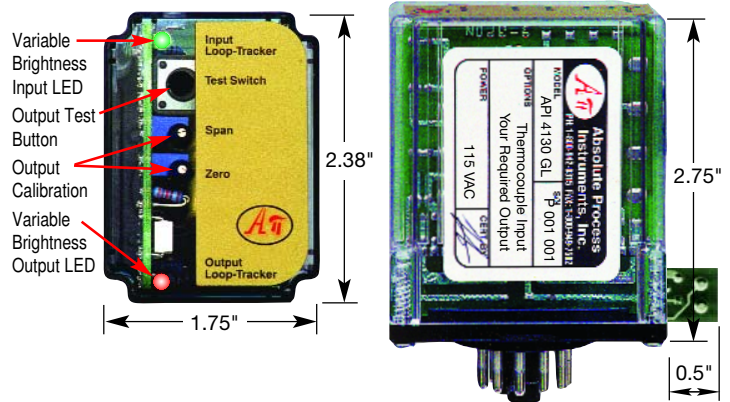

## Description and Features

The **API 4130 GL** accepts a thermocouple input and provides a DC voltage or current output. The **API 4130 GL** provides a DC voltage or current output that is optically isolated from input to output and linear to the process temperature for applications requiring ground loop elimination, common mode signal rejection, or noise pickup reduction. The module power supply is also isolated from the input and output.

The **API 4130 GL** is factory configured for thermocouple type, temperature span ( $^{\circ}\text{C}$  or  $^{\circ}\text{F}$ ), and DC voltage or current output. Automatic cold-junction compensation and upscale burnout protection are standard, downscale burnout protection is optional. Minimum and maximum temperature spans are dependent upon the T/C type. Consult the factory to confirm your specific requirements.

The **API 4130 GL** features a thermocouple connection block on the side of the module rather than the mounting base. This allows direct temperature compensation circuitry at the T/C termination point eliminating cold junction errors commonly found when wiring through the mounting base.

API exclusive features include two **LoopTracker** LEDs and a **Functional Test Pushbutton**. The LoopTracker LEDs (Green for input, Red for output) vary in intensity with changes in the process input and output signals. Monitoring the state of these LEDs can provide a quick visual picture of your process loop at all times. The functional test pushbutton provides a fixed output (independent of the input) when held depressed. The test output level is fixed at 50% of output span. Both the LoopTracker LEDs and functional test pushbutton greatly aid in saving time during initial startup and/or troubleshooting.

The **API 4130 GL** plugs into an industry standard 8-pin octal socket sold separately. Sockets **API 008** and finger-safe **API 008 FS** allow either DIN rail or panel mounting.

## Models & Options

Factory Configured—Specify T/C type,  $^{\circ}\text{F}/^{\circ}\text{C}$  range, output range, and options

**API 4130 GL** Isolated thermocouple transmitter, 115 VAC powered

Options—Add to end of model number

<b>P</b>	Powered by 80-265 VAC or 48-300 VDC, 50/60 Hz
<b>A230</b>	Powered by 230 VAC, 50/60 Hz
<b>D</b>	Powered by 9-30 VDC
<b>B</b>	Downscale T/C burnout protection instead of upscale
<b>HA</b>	High accuracy linearization to $\pm 0.2\%$ of span
<b>EXTSUP</b>	Open collector output when a "sinking" output is required
<b>U</b>	Conformal coating for moisture resistance

Accessories—Order as separate line item

<b>API 008</b>	8-pin socket
<b>API 008 FS</b>	8-pin finger-safe socket
<b>API TK36</b>	DIN rail, 35 mm W x 39" L, aluminum



## ELECTRICAL CONNECTIONS

**WARNING!** All wiring must be performed by qualified personnel only. This module requires an industry-standard 8-pin socket. Order API 008 or finger-safe API 008 FS socket separately.

**Power Input Terminals** – The white label on the side of the API module will indicate the power requirements. AC power is connected to terminals 1 and 3. For DC powered modules, polarity **MUST** be observed. Positive (+) is wired to terminal 1 and negative (-) is wired to terminal 3.

**Thermocouple Input** – The connection block is located on the side of the module. Polarity must be observed. With thermocouples, the red wire is connected to the negative (-) terminal.

**Signal Output Terminals** – Polarity must be observed when connecting the signal output to the load. The positive connection (+) is connected to terminal 7 and the negative (-) is connected to terminal 8.

Note that with current outputs the module provides power to the output loop unless option EXTSUP was ordered for a sinking output requirement.

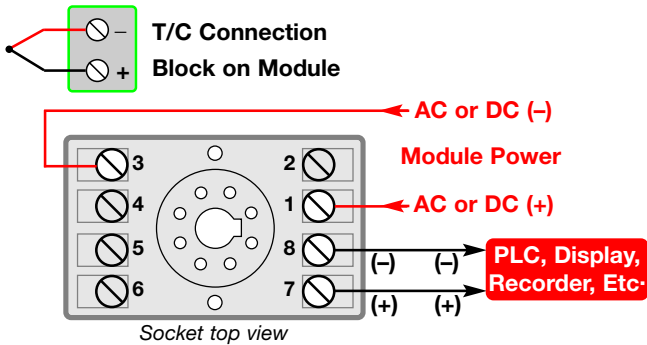

API 4130 GL typical wiring

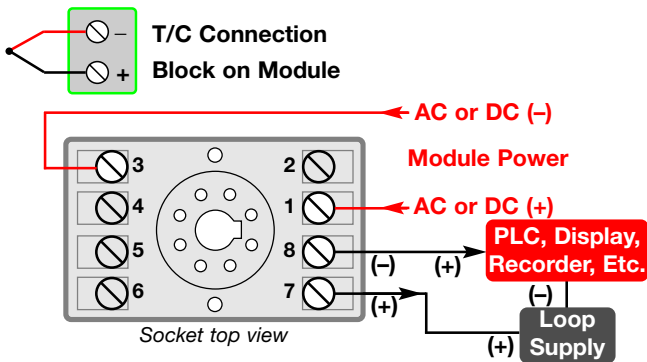

API 4130 GL EXTSUP typical wiring

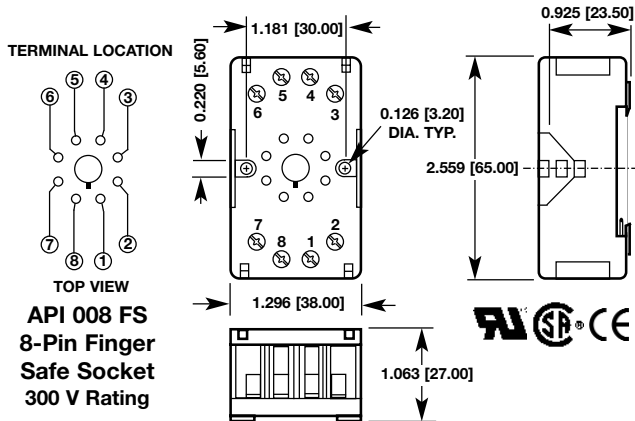

## CALIBRATION

The API 4130 GL is factory configured to your exact input and output requirements.

Input and output ranges are listed on the module label. Input changes require factory modification. Field calibration of the input is NOT recommended and may void the warranty. Top-mounted, Zero and Span potentiometers can be used should fine-tuning of the output be necessary.

1. Apply power to the module and allow a minimum 20 minute warm up time.
2. Using an accurate thermocouple simulator, provide an input to the module equal to the minimum input required for the application.
3. Connect an accurate measurement device to the output. Adjust the Zero potentiometer for the exact minimum output desired. The Zero control should only be adjusted when the input signal is at its minimum to produce the corresponding minimum output signal. Example: for a 4-20 mA output signal, the Zero control will allow adjustment of the 4 mA or low end of the signal.
4. Set the input at maximum, and then adjust the Span pot for the exact maximum output desired. The Span control should only be adjusted when the input signal is at its maximum. This will produce the corresponding maximum output signal. Example: for 4-20 mA output signal, the Span control will provide adjustment for the 20 mA or high end of the signal.
5. Repeat adjustments for maximum accuracy.

## TEST BUTTON

The Test pushbutton provides approximately 50% output when depressed. This will drive the device on the output side of the loop (a panel meter, chart recorder, etc.) with a known good signal that can be used as a system diagnostic aid during initial start-up or during troubleshooting. When released, the output will return to normal.

Example: If you are checking a 4-20 mA current loop, when the pushbutton is held depressed, the output from the module will be approximately 12 mA.

## OPERATION

The API 4130 GL is factory configured to your exact input and output requirements. The input circuitry filters the T/C input, applies the cold-junction compensation, and amplifies the low-level T/C signal. The amplified signal first passes through an optical isolator, then is passed to the output stage where it is corrected for the inherent non-linearity of the specified T/C type and scaled to the desired output range.

**GREEN LoopTracker® Input LED** – Provides a visual indication that a signal is being sensed by the input circuitry of the module. It also indicates the input signal strength by changing in intensity as the process changes from minimum to maximum. If the LED fails to illuminate, or fails to change in intensity as the process changes, this may indicate a problem with module power or signal input wiring.

**The RED LoopTracker Output LED** – Provides a visual indication that the output signal is functioning. It becomes brighter as the input and the corresponding output change from minimum to maximum. For current outputs, the red LED will only light if the output loop current path is complete. For either current or voltage outputs, failure to illuminate or a failure to change in intensity as the process changes may indicate a problem with the module power or signal output wiring.

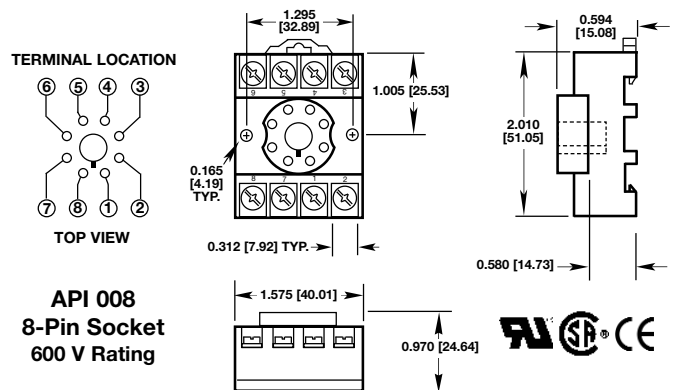

API maintains a constant effort to upgrade and improve its products. Specifications are subject to change without notice. Consult factory for your specific requirements.