

AC to DC Isolated Transmitter

API 6380 G, API 6380 G HV



Input: 0-50 mV to 0-600 VAC, 0-5 mA to 200 mAAC
Output: 0-1 VDC to ±10 VDC or 0-2 mA to 0-25 mADC



Field Rangeable I/O
One Minute Setup!

- Non-Interactive Zero/Span Controls
- Set-Up via Rotary Switches & Easy-to-Use Tables
- Internal Jumper for Reverse Output
- Full 2000 V Isolation Input/Output/Power
- Input and Output LoopTracker® LEDs
- Functional Test Pushbutton

Applications

- Convert AC Signals to DC Process Signals
- Min./Max. Ripple Monitoring

Specifications

Input Ranges

System voltages must not exceed socket voltage rating

	Minimum	Maximum
Voltage:	0 to 50 mVAC	0 to 250 VAC
Current:	0 to 4 mAAC	0 to 200 mAAC

Current inputs greater than 200 mAAC require the **5A** external shunt resistor option

API 6380 G HV: 0 to 300 VAC, 0-400 VAC, 0-500 VAC, 0-600 VAC input ranges in addition to standard ranges

Input Impedance

With 0-4 volt input:	1 MΩ minimum
With > 4 volt input:	220 kΩ minimum
Current input:	10 Ω

Input Frequency

40 Hz to 1000 Hz sinusoidal input

Input Loop Power Supply

18 VDC nom., unregulated, 25 mADC, max. ripple, less than 1.5 V_{p-p}

LoopTracker

Variable brightness LEDs indicate input/output loop level and status

Output Ranges

	Minimum	Maximum	Load Factor
Voltage:	0-1 VDC	0-10 VDC	
Bipolar Voltage:	±1 VDC	±10 VDC	
Current (20 V compliance):	0-2 mADC	0-25 mADC	1000 Ω at 20 mA

Consult factory for other ranges

Output Logic

Standard: Normal acting. Internal jumper for output reversal.

Output Linearity

Better than ±0.1% of span

Output Zero and Span

Multiturn potentiometers to compensate for load and lead variations ±15% of span adjustment range typical

Functional Test Button

Sets output to test level when pressed. Potentiometer factory set to approximately 50% of span, adjustable 0-100% of span

Response Time (0-90%)

200 milliseconds typical

Isolation

2000 V_{RMS} minimum

Full isolation: power to input, power to output, input to output

Ambient Temperature Range and Temperature Stability

-10°C to +60°C operating ambient

Better than ±0.02% of span per °C stability

Power

Standard:	115 VAC ±10%, 50/60 Hz, 2.5 W max.
P	80-265 VAC or 48-300 VDC, 50/60 Hz, 2.5 W typical
A230 option:	230 VAC ±10%, 50/60 Hz, 2.5 W max.
D option:	9-30 VDC, 2.5 W typical

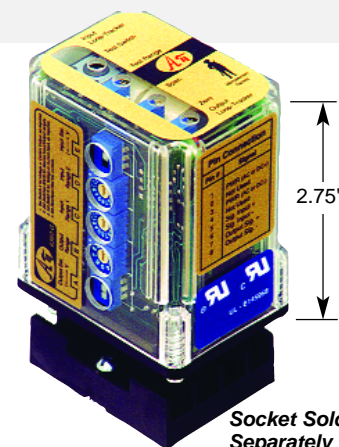
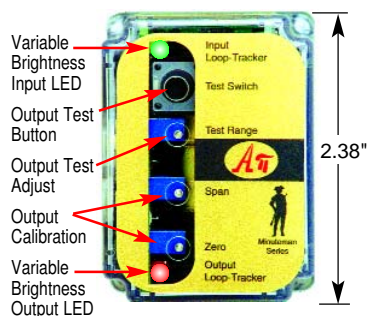

Socket Sold Separately



Description and Features

The **API 6380 G** accepts an AC voltage or current input and provides an optically isolated DC voltage or current output that is linearly related to the input. Accuracy is maintained over a wide frequency range for maximum flexibility. The **API 6380 G** is commonly used to monitor line voltage or current (either direct or with the use of a CT) for speed control, preventive maintenance, load shedding, etc. For non-sinusoidal inputs, refer to the true RMS model **API 6380 G S**. The full 3-way (input, output, power) isolation makes this module useful for ground loop elimination, common mode signal rejection or noise pickup reduction.

20 input and 16 output ranges can be field-configured via external rotary and slide switches. Popular ranges are listed on the module label. Consult the factory for assistance with special ranges. For current inputs greater than 200 mAAC a current shunt is required. Specify option **5A** for inputs up to 5 AAC. Use of unapproved sockets or current shunts may void the module warranty.

API exclusive features include two **LoopTracker** LEDs and a **Functional Test Pushbutton**. The LoopTracker LEDs (Green for input, Red for output) vary in intensity with changes in the process input and output signals. Monitoring the state of these LEDs can provide a quick visual picture of your process loop at all times. The functional test pushbutton provides a fixed output (independent of the input) when held depressed. The test output level can be field-adjusted via a multiturn potentiometer.

Both the LoopTracker LEDs and functional test pushbutton greatly aid in saving time during initial startup and/or troubleshooting. The built-in 18 VDC unregulated loop excitation power supply can be used to power passive input devices.

The **API 6380 G** plugs into an industry standard 8-pin octal socket sold separately. Sockets **API 008** and finger-safe **API 008 FS** allow either DIN rail or panel mounting.

Models & Options

API 6380 G Field rangeable AC to DC isolated transmitter, w. loop supply, 115 VAC

API 6380 G HV Field rangeable High Voltage AC to DC isolated transmitter, w. loop supply, 115 VAC,

Options—Add to end of model number

P	Powered by 80-265 VAC or 48-300 VDC, 50/60 Hz
A230	Powered by 230 VAC, 50/60 Hz
D	Powered by 9-30 VDC
5A	Up to 5 amp AC input with socket and 25 W shunt
HV	High voltage input to 600 VAC
U	Conformal coating for moisture resistance

Accessories—Order as separate line item

API 008	8-pin socket
API 008 FS	8-pin finger-safe socket
API TK36	DIN rail, 35 mm W x 39" L, aluminum
CT	See Current Sensor data sheets for current transformers



ELECTRICAL CONNECTIONS

WARNING! All wiring must be performed by qualified personnel only. This module requires an industry-standard 8-pin socket. Order API 008 or finger-safe API 008 FS socket separately. Input voltages must not exceed socket voltage rating.

Power Input Terminals – The white label on the side of the API module will indicate the power requirements. AC power is connected to terminals 1 and 3. For DC powered modules, polarity **MUST** be observed. Positive (+) is wired to terminal 1 and negative (-) is wired to terminal 3.

Signal Input – Connect the AC signal input to terminals 5 and 6. Maximum voltage input is 250 VAC. Maximum current input is 200 mAAC. Higher current input requires the use of the optional 5 A current shunt.

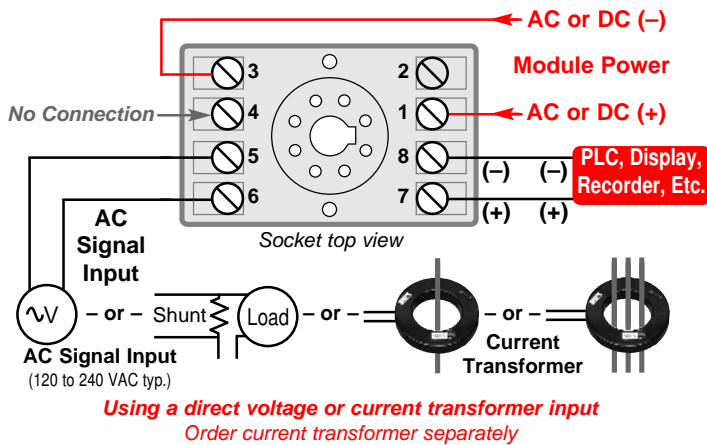

18 V Supply – A passive input device can be powered by the 18 Volt DC power supply at terminal 4 (+) and terminal 5 (-) although it is typically not used for an AC input. It is very important to consult the manufacturer of your specific sensor to determine its compatibility and proper wiring.

Signal Output Terminals – Polarity must be observed when connecting the signal output to the load. The positive connection (+) is connected to terminal 7 and the negative (-) is connected to terminal 8. The API 6380 G provides power to the output loop.

RANGE SELECTION

Three rotary switches and two slide switches located on the side of the module are used to select input and output ranges. Most popular ranges are listed on the module labels. See www.api-usa.com or contact factory for special ranges.

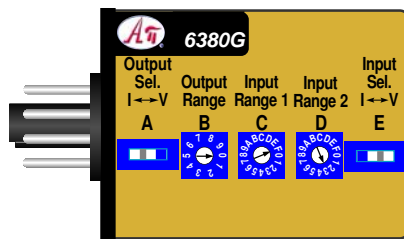

1. Set the **OUTPUT SELECT** slide switch to current (I) or voltage (V) depending on output type.
2. Set the **INPUT SELECT** slide switch to current (I) or voltage (V) depending on output type. The input selector switch determines the input impedance for the module, typically 50 Ω for current inputs and 1 M Ω or greater for voltage inputs.
3. From the table, find the rotary switch combination that matches your input and output ranges.
4. Set the three rotary switches **B**, **C**, and **D** to the values found in the table.
5. The Zero, Span and Test Range potentiometers can now be adjusted for the desired output range.

Depending on the rotary switch settings, the input is filtered, either amplified or attenuated as required, then passed through an optical isolation circuit to the output stage.

CALIBRATION

Input & Output Ranges – Ranges are pre-set at the factory as specified on your order. Top-mounted, Zero and Span potentiometers can be used should fine-tuning be necessary. Custom ranges may require factory modification.

1. Apply power to the module and allow a minimum 20 minute warm up time.
2. Using an accurate calibration source, provide an input to the module equal to the minimum input required for the application.
3. Using an accurate measurement device for the output, adjust the Zero potentiometer for the exact minimum output desired. The Zero control should only be adjusted when the input signal is at its minimum. This will produce the corresponding minimum output signal.
4. Set the input at maximum, and adjust the Span pot for the exact maximum output desired. The Span pot should only be adjusted when the input signal is at its maximum. This will produce the corresponding maximum output signal.
5. Repeat adjustments for maximum accuracy.

Test Range Adjust – Turn the multi-turn Test Range potentiometer while holding the Test button depressed until the desired output test level is reached. It can be adjusted to vary the output signal from 0 to 100% of the output range.

OPERATION

The API 6380 G Input selector switch determines the input impedance for the module, typically 10 Ω for current inputs, 1 M Ω minimum for voltage inputs from 0-4 VAC, and 220 k Ω minimum for voltage inputs greater than 4 VAC.

Depending on the rotary switch settings, the input is either amplified or attenuated as required, then filtered and processed by a precision full-wave rectification circuit. The result is passed thru a low pass active filter that provides a DC voltage representing the average value of the input. This DC voltage is passed through an optical isolation circuit to the output stage.

The rotary switch settings and Output selector switch determine the exact DC voltage or current output available.

Test Button – Drives a device on the output side of the loop (a panel meter, chart recorder, etc.) with a known good signal that can be used as a system diagnostic aid during initial start-up or during troubleshooting. When released, the output will return to normal.

GREEN LoopTracker® Input LED – Provides a visual indication that a signal is being sensed by the input circuitry of the module. It also indicates the input signal strength by changing in intensity as the process changes from minimum to maximum. If the LED fails to illuminate, or fails to change in intensity as the process changes, this may indicate a problem with module power or signal input wiring.

RED LoopTracker output LED – Provides a visual indication that the output signal is functioning. It becomes brighter as the input and the corresponding output change from minimum to maximum. For current outputs, the RED LED will only light if the output loop current path is complete. For either current or voltage outputs, failure to illuminate or a failure to change in intensity as the process changes may indicate a problem with the module power or signal output wiring.

		INPUT RANGES												
		Switch E to "V"							Switch E to "I"					
		0-50 mV	0-100 mV	0-500 mV	0-5 V	0-20 V	0-125 V	0-200 V	0-250 V	0-10 mA	0-100 mA	0-200 mA		
		BCD	BCD	BCD	BCD	BCD	BCD	BCD	BCD	BCD	BCD	BCD		
OUTPUT RANGES	Switch A to "V"	0-1 V	0A2	022	002	0E2	0F2	049	052	0D9	022	092	012	
		0-2 V	8A2	822	802	8E2	8F2	849	852	8D9	822	892	812	
		0-4 V	1A2	122	102	1E2	1F2	149	152	1D9	122	192	112	
		1-5 V	6A2	622	602	6E2	6F2	649	652	6D9	622	692	612	
		0-5 V	9A2	922	902	9E2	9F2	949	952	9D9	922	992	912	
		0-10 V	3A2	322	302	3E2	3F2	349	352	3D9	322	392	312	
		±5 V	4A2	422	402	4E2	4F2	449	452	4D9	422	492	412	
		±10 V	5A2	522	502	5E2	5F2	549	552	5D9	522	592	512	
		A to "I"	4-20 mA	7A2	722	702	7E2	7F2	749	752	7D9	722	792	712
			0-20 mA	3A2	322	302	3E2	3F2	349	352	3D9	322	392	312

API maintains a constant effort to upgrade and improve its products. Specifications are subject to change without notice. Consult factory for your specific requirements.



RANGE SELECTION

Three rotary switches and two slide switches located on the side of the module are used to select input and output ranges. Popular ranges are listed on the module labels. See table below for a complete listing or contact factory for special ranges.

1. Set the **OUTPUT SELECT** slide switch to current (I) or voltage (V) depending on output type.
2. Set the **INPUT SELECT** slide switch to current (I) or voltage (V) depending on output type. The input selector switch determines the input impedance for the module, typically 50 Ω for current inputs and 1 MΩ or greater for voltage inputs.
3. From the table, find the rotary switch combination that matches your input and output ranges.
4. Set the three rotary switches **B**, **C**, and **D** to the values found in the table.
5. The Zero, Span and Test Range potentiometers can now be adjusted for the desired output range.

Depending on the rotary switch settings, the input is filtered, either amplified or attenuated as required, then passed through an optical isolation circuit to the output stage.

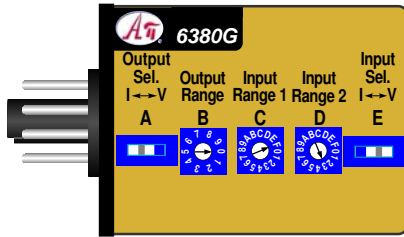

		API 6380 G HV INPUT RANGES				
		Switch E to "V"				
		0-300 VAC	0-400 VAC	0-500 VAC	0-600 VAC	
		BCD	BCD	BCD	BCD	
OUTPUT RANGES	Rotary Switches →					
	Switch A to "V"	0-1 V	0D3	0D0	059	053
	0-2 V	8D3	8D0	859	853	
	0-4 V	1D3	1D0	159	153	
	1-5 V	6D3	6D0	659	653	
	0-5 V	9D3	9D0	959	953	
	0-8 V	2D3	2D0	259	253	
	2-10 V	7D3	7D0	759	753	
	0-10 V	3D3	3D0	359	353	
	±5 V	4D3	4D0	459	453	
±10 V	5D3	5D0	559	553		
Switch A to "I"	0-2 mA	0D3	0D0	059	053	
2-10 mA	6D3	6D0	659	653		
0-10 mA	9D3	9D0	959	953		
0-16 mA	2D3	2D0	259	253		
4-20 mA	7D3	7D0	759	753		
0-20 mA	3D3	3D0	359	353		

AC Input

		API 6380 G, API 6380 G HV INPUT RANGES																				
		Switch E to "V"										Switch E to "I"										
		0-50 mV	0-100 mV	0-200 mV	0-500 mV	0-1 V	0-2 V	0-5 V	0-10 V	0-20 V	0-50 V	0-100 V	0-125 V	0-175 V	0-200 V	0-250 V	0-5 mA	0-10 mA	0-50 mA	0-100 mA	0-200 mA	
		BCD	BCD	BCD	BCD	BCD	BCD	BCD	BCD	BCD	BCD	BCD	BCD	BCD	BCD	BCD	BCD	BCD	BCD	BCD	BCD	
OUTPUT RANGES	Rotary Switches →																					
	Switch A to "V"	0-1 V	0A2	022	0B2	002	092	012	0E2	062	0F2	042	0D2	049	054	052	0D9	0A2	022	002	092	012
	0-2 V	8A2	822	8B2	802	892	812	8E2	862	8F2	842	8D2	849	854	852	8D9	8A2	822	802	892	812	
	0-4 V	1A2	122	1B2	102	192	112	1E2	162	1F2	142	1D2	149	154	152	1D9	1A2	122	102	192	112	
	1-5 V	6A2	622	6B2	602	692	612	6E2	662	6F2	642	6D2	649	654	652	6D9	6A2	622	602	692	612	
	0-5 V	9A2	922	9B2	902	992	912	9E2	962	9F2	942	9D2	949	954	952	9D9	9A2	922	902	992	912	
	0-8 V	2A2	222	2B2	202	292	212	2E2	262	2F2	242	2D2	249	254	252	2D9	2A2	222	202	292	212	
	2-10 V	7A2	722	7B2	702	792	712	7E2	762	7F2	742	7D2	749	754	752	7D9	7A2	722	702	792	712	
	0-10 V	3A2	322	3B2	302	392	312	3E2	362	3F2	342	3D2	349	354	352	3D9	3A2	322	302	392	312	
	±5 V	4A2	422	4B2	402	492	412	4E2	462	4F2	442	4D2	449	454	452	4D9	4A2	422	402	492	412	
±10 V	5A2	522	5B2	502	592	512	5E2	562	5F2	542	5D2	549	554	552	5D9	5A2	522	502	592	512		
Switch A to "I"	0-2 mA	0A2	022	0B2	002	092	012	0E2	062	0F2	042	0D2	049	054	052	0D9	0A2	022	002	092	012	
2-10 mA	6A2	622	6B2	602	692	612	6E2	662	6F2	642	6D2	649	654	652	6D9	6A2	622	602	692	612		
0-10 mA	9A2	922	9B2	902	992	912	9E2	962	9F2	942	9D2	949	954	952	9D9	9A2	922	902	992	912		
0-16 mA	2A2	222	2B2	202	292	212	2E2	262	2F2	242	2D2	249	254	252	2D9	2A2	222	202	292	212		
4-20 mA	7A2	722	7B2	702	792	712	7E2	762	7F2	742	7D2	749	754	752	7D9	7A2	722	702	792	712		
0-20 mA	3A2	322	3B2	302	392	312	3E2	362	3F2	342	3D2	349	354	352	3D9	3A2	322	302	392	312		

DuoPak NEED 2 I/O CHANNELS? SEE PAGE 19



Monitoring a Current Transformer

PROBLEM

A current transformer (CT) has an output of 0 to 5 amps depending on the motor current. The readings need to be monitored by a PLC that accepts a 4-20 mA input.

SOLUTION

Use an **API 6380 G 5A** isolated DC to DC transmitter with the optional 5 Amp current shunt to convert the 0-5 A signal to 4-20 mA. The module switches are set so that 0 A = 4 mA and 5 A = 20 mA.

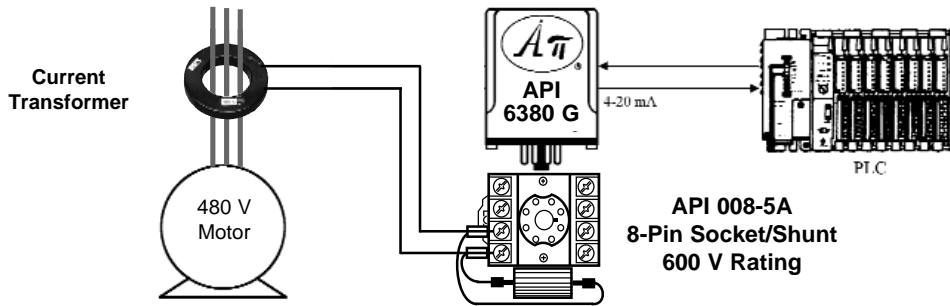

API Sockets and Shunts

TERMINAL LOCATION

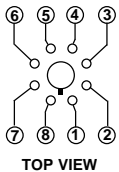

API 008
8-Pin Socket
600 V Rating

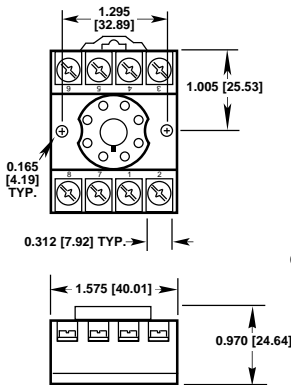

TERMINAL LOCATION

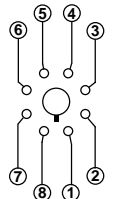

API 008 FS
8-Pin Finger
Safe Socket
300 V Rating

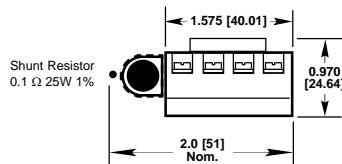
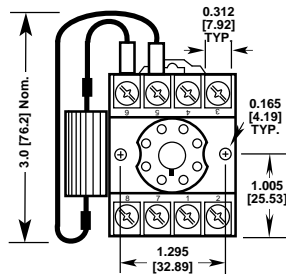
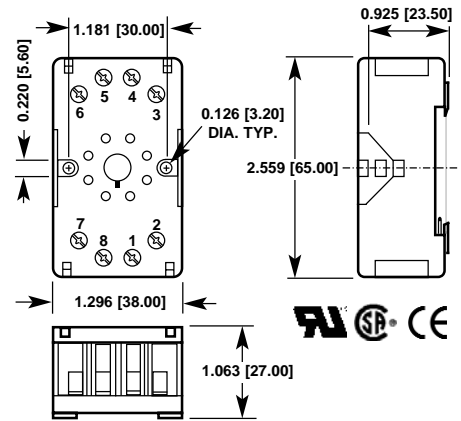

API 008-5A
8-Pin Socket/Shunt
600 V Rating



FREE APPLICATION ASSISTANCE

Call Customer Service

800-942-0315

API maintains a constant effort to upgrade and improve its products. Specifications are subject to change without notice. Consult factory for your specific requirements.