



Input: Up to 4 Strain Gauges or Load Cells *Individual Excitation & Trim*

Output: Use with API 4058 G or API 4059 G

- Sums up to 4 Strain Gauges or Load Cells
- Available with Field-Rangeable Signal Conditioner
- 4 Excitation and Signal Trim Potentiometers
- Switch for Internal or External Excitation Voltage

Applications

- Platform Scales & Weighing systems
- Easy Setup & Adjustment of Load Cells
- Easy Summation of Multiple Strain Gauges

Specifications

Input

1 to 4 strain gauges, bridges, or load cells
4 switches to enable or disable individual strain gauges

Strain Gauge Connections

Individual terminal blocks for up to 4 strain gauges with provisions for signal (+), signal (-), signal shield, excitation (+), and excitation (-)

Strain Gauge Trim Adjustment

4 multiturn potentiometers to adjust output of each strain gauge

Excitation Supply

Switch to select internal (with API 4058 or API 4059) or customer-provided external excitation supply

Terminals provided for connecting external excitation

Excitation Supply Adjustment

4 multiturn potentiometers to adjust excitation voltage for each strain gauge to compensate for lead variations

Signal Conditioner Socket

Standard 11-pin socket. See other side for pin-out diagram.

Output Connection

Signal (+) and signal (-) terminals for combined output signal

Power Connection

Terminals for AC or DC external power and ground

Specifications with API 4058 or API 4059

Power

Standard: 115 VAC, 2.5 Watts maximum
P option: API 4058 only, 80-265 VAC or 48-300 VDC, 50/60 Hz, 2.5 W typ.
A230 option: 230 VAC $\pm 10\%$, 50/60 Hz, 2.5 W max.
D option: 9-30 VDC, 3 W typical with 4 load cells

Strain Gauge Excitation Supply

Field-rangeable from 1 to 10 VDC

Strain Gauge Sensitivity

Field-rangeable from 0.5 mV/V up to 120 mV/V

Strain Gauge Signal

Field-rangeable from 5 mVDC to 1200 mVDC with the API 4058 G
Field-rangeable from 5 mVDC to 400 mVDC with the API 4059 G

Outputs

Field-rangeable DC voltage or current
DC voltages from -10 VDC to +10 VDC
DC currents up to 20 mA DC at 20 VDC compliance

Board Only

6.85" wide x 8.75" high x 0.75" deep

Signal Conditioner and Board

6.85" wide x 8.75" high x 3.75" deep



API SUM 000

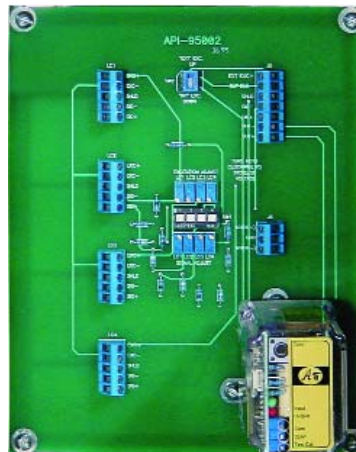
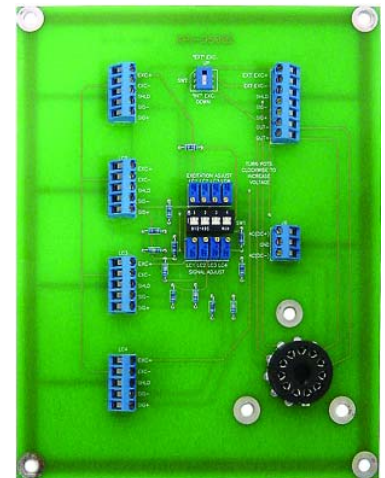

API SUM 025

Description and Features

The API-SUM xxx strain gauge summing assembly consists of a sum board and an optional, field-rangeable strain gauge signal conditioner that plugs into an existing socket on the board. The board will accept up to four 350 Ω (or greater) strain gauges (load cells) and with the signal conditioner provide a DC voltage or current output proportional to the sum of the active strain gauges.

API exclusive features include four excitation trim potentiometers, four signal trim potentiometers, a switch to select internal or external excitation voltage and switches to activate or deactivate individual load cells. These features allow easy setup, testing, and calibration of many types of weighing systems.

Models & Options

Common API-SUM xxx configurations are listed below. Consult factory for special configurations to meet your requirements.

API SUM 000 Summing board only

For applications where no on-board signal conditioning or enclosure is required. Customer is responsible for proper installation inside a protective enclosure.

API SUM 025 Summing board with API 4059

Summing assembly board with API 4059 strain gauge signal conditioner. For installation in an existing or customer supplied enclosure. Customer is responsible for proper installation inside a protective enclosure.

Strain/Load Cell



INSTALLATION AND ELECTRICAL CONNECTIONS

WARNING! All wiring must be performed by a qualified electrician or instrumentation engineer.

For protection, the API-SUM xxx board must be mounted in an appropriate enclosure. We recommend mounting it in a NEMA 4 or NEMA 4X enclosure depending on your requirements.

The sum board includes several terminal blocks for wiring the four load cells, AC or DC power, DC voltage or current output, external excitation and signal output.

For detailed instructions, refer to both the API-SUM xxx instruction manual and the strain gauge signal conditioner data sheet.

CALIBRATION SUMMARY

Separate excitation and signal trim pots are used for individual fine-tuning of each strain gauge. Slide switches allow each strain gauge to be switched in or out of the circuit as required. Another slide switch allows switching between internal and external excitation supply. For detailed calibration instructions refer to both the API-SUM xxx instruction manual and the strain gauge signal conditioner data sheet.

If the optional signal conditioner is being used, it must first be calibrated to the proper excitation voltage, input sensitivity and DC voltage or current output. These parameters are dependent upon the specifications of the strain gauges being used as well as the desired process output.

If no signal conditioner is being used, ensure that the external excitation switch position is selected and wired accordingly.

1. Complete all wiring and module calibration.
2. Turn each Excitation Trim potentiometer fully clockwise.
3. Measure the excitation voltage for each strain gauge. Adjust as necessary to equalize the voltages.
4. Apply a known weight sequentially over each strain gauge and measure the sensitivity voltage of each strain gauge being used. Record these readings.
5. Again apply the known weight over each strain gauge and adjust the Signal Trim potentiometer for that cell so that the meter reads the same as the lowest value recorded.
6. Fine-tune the offset, zero and span of the signal conditioner as required.

OPERATION

The API-SUM xxx strain gauge summing assembly consists of a sum board and an optional, field-rangeable strain gauge signal conditioner that plugs into an existing socket on the board. The board will accept up to four 350 Ω (or greater) strain gauges (load cells).

The optional strain gauge signal conditioner provides a field-rangeable excitation supply (from 1 to 10 VDC) to each strain gauge, receives the resulting mVDC signal back from each strain gauge, sums these signals and provides a single DC voltage or current output in proportion to this sum.

The signal conditioner can also be field-ranged for input sensitivities from 0.5 to 120 mV/V (signals up to 1200 mVDC), DC voltage outputs up to ±10 VDC or DC current outputs up to 20 mADC. An offset adjustment on the signal conditioner allows the user to cancel or tare non-zero deadweights in the application.

API exclusive features four excitation trim potentiometers, four signal trim potentiometers, a switch to select internal or external excitation voltage and switches to activate or deactivate individual load cells. These features allow easy setup, testing, and calibration of many types of weighing systems.

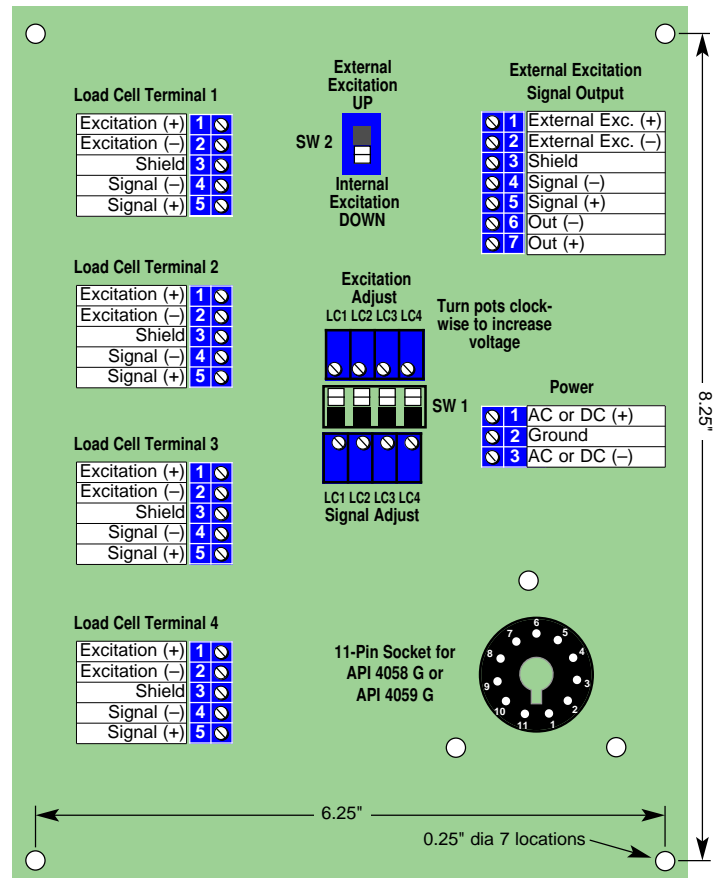

Board Dimensions: 6.85" W x 8.75" high x 0.7" deep
Board Material Thickness: 0.094"

API maintains a constant effort to upgrade and improve its products. Specifications are subject to change without notice. Consult factory for your specific requirements.