



Input: 0-50 Amps DC to 0-400 Amps DC
Output: 4-20 mA

- Low Voltage AC or DC Powered
- Isolated Output
- Hall-Effect Sensor
- Jumper Selectable Ranges

Models and Ranges

CTX-DC-0	4-20 mA output, jumper selectable ranges 0 to 50 Amps 0 to 75 Amps 0 to 100 Amps
CTX-DC-1	4-20 mA output, jumper selectable ranges 0 to 100 Amps 0 to 150 Amps 0 to 200 Amps
CTX-DC-2	4-20 mA output, jumper selectable ranges 0 to 150 Amps 0 to 225 Amps 0 to 300 Amps
CTX-DC-3	4-20 mA output, jumper selectable ranges 0 to 200 Amps 0 to 300 Amps 0 to 400 Amps



DC Current

Specifications

Output

4-20 mA DC source

Output Limit

23 mA DC

Power Supply

20 to 50 VDC or 22 to 38 VAC
 Power input and output signal not isolated

Power

2 VA

Output Load

650 ohms maximum

Accuracy

±0.8% full scale

Linearity

±0.75% full scale

Response Time

100 milliseconds (to 90% step change)

Frequency Range

DC only

Isolation Voltage

3000 V monitored line to output

Sensing Aperture

0.85" x 0.85" square (21.5 mm x 21.5 mm)

Case

UL 94V-0 flammability rated

Environmental

-4 to 122 °F (-20 to 50 °C), 0-95% RH, non-condensing

Dimensions

Width: 1.18" (30.0 mm)
 Length: 3.53" (89.7 mm)
 Height: 2.70" (68.6 mm)

Features and Description

The **CTX-DC** series transmitters convert DC current as high as 400 Amps DC to an isolated 4-20 mA DC output. The design consists of a hall effect sensor and a signal conditioner in one compact split core package. Typical applications include measuring battery loads or battery charging currents, heater loads, or other DC currents, for preventive maintenance, overload protection, or control.

The **CTX-DC** series transmitters have a built-in hall effect sensor that physically isolates the high DC current from the 4-20 mA output making this product much safer to use than other products or methods. In addition, the non-intrusive design eliminates the insertion loss that exists when DC shunts are used.

Installation, wiring and configuration are simple. The transmitters are designed to withstand harsh industrial environments. They can be mounted in virtually any position and either panel mounted using the built-in mounting bracket or hung directly on the wire and secured with a wire tie. Due to the split core design, these models are easily and quickly installed in existing or new circuits by snapping the core shut around the wire to be measured.

Four different models are available, each configurable by the user to one of three specific ranges by changing a jumper.

The transmitter can be powered by either 22 to 38 VAC or 20 to 50 VDC. Due to internal power regulation, it will work well with an unregulated power source. The transmitter also powers the 4-20 mA current loop simplifying installation.



CTX-DC Series Installation and Setup

DESCRIPTION

CTX-DC series transducers combine a hall effect sensor and a signal conditioner into a single package. This provides higher accuracy, lower wiring costs, easier installation and saves valuable panel space. The CTX-DC series provides a 4-20 mA output proportional to the DC current flowing through the aperture.

INSTALLATION

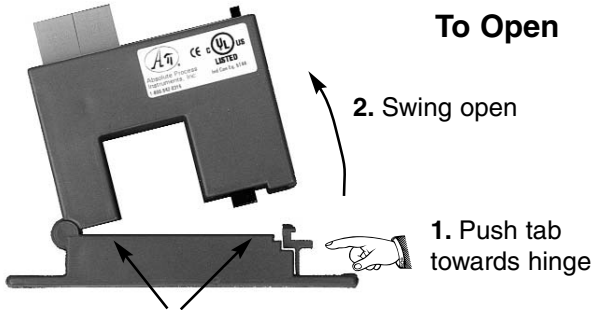

IMPORTANT!
Keep contact areas clean!

Press the tab in the direction as shown to open the sensor.

After placing the wire in the opening, press the hinged portion firmly downward until a definite click is heard and the tab pops out fully.

CTX-DC series transducer work in the same environment as motors, contactors, heaters, pull-boxes, and other electrical enclosures.

They can be mounted in any position or hung directly on wires with a wire tie. Just leave at least one inch distance between sensor and other magnetic devices.

KEEP SPLIT-CORE CONTACT AREAS CLEAN!

Silicone grease is factory applied on the mating surfaces to prevent rust and improve performance. Be careful not to allow grit or dirt onto the grease in the contact area. Operation can be impaired if the mating surfaces do not have good contact. Check visually before closing.

OUTPUT WIRING

Connect control or monitoring wires to the sensor using the wiring diagram below.

Note that if DC power is used, the negative of the power supply is considered to be common with the negative of the 4-20 mA output loop.

Use up to 14 AWG solid or stranded copper wire and tighten terminals to 3.5 inch-pounds torque.

Be sure the loop resistance does not exceed 650 ohms.

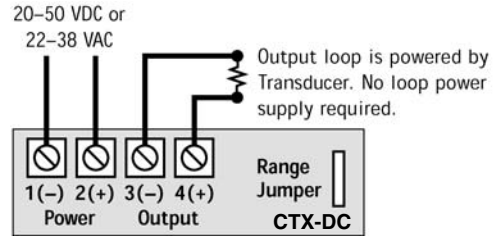

RANGE SELECTION

CTX-DC series transducers feature field selectable ranges. The ranges are factory calibrated and there is no need to field set zero or span.

- Determine the normal operating amperage of your monitored circuit.
- Select the range that is equal to or slightly higher than the normal operating amperage.
- Place the range jumper in the appropriate position.

TROUBLESHOOTING

1. Sensor has no output

- Input power supply power supply problem. Check wiring and voltage.
- Output wiring polarity is incorrect. Check and correct wiring polarity according to diagram above.
- The core contact area may be dirty. Open the sensor and clean the contact area.

2. Output signal too low

- Too much burden on output loop. Make sure loop does not exceed 650 ohms.
- The jumper may be set in a range that is too high for current being monitored. Move jumper to the correct range.
- Monitored current is below minimum required. Loop the monitored wire several times through the aperture until the "sensed" current rises above minimum.

$$\text{Sensed Amps} = (\text{Actual Amps}) \times (\text{Number of Loops})$$

Count loops on the inside of the aperture only.

3. Sensor is always at 4 mA

- Monitored load is not DC or is not on. Check that the load is DC and that it is actually on.

4. Output Signal is always at 20 mA

- The jumper may be set in a range that is too low for current being monitored. Move jumper to the correct range.

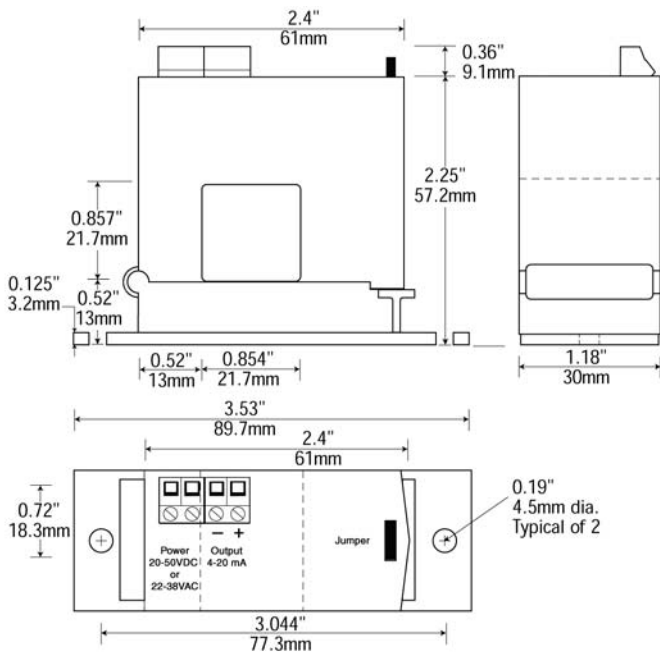

API maintains a constant effort to upgrade and improve its products. Specifications are subject to change without notice. Consult factory for your specific requirements.