



Input: Up to ± 200 VDC
Output: 0-1 V to ± 10 VDC or 0-2 mA to 4-20 mA

Wide Ranging I/O
One Minute Setup!



- One Minute Setup for Hundreds of I/O Ranges
- External Switches & Tables for Range Selection
- 2000 V Isolation Input/Output/Power
- Input and Output LoopTracker® LEDs
- Functional Test Pushbutton

Applications

- Isolate, Convert, Boost, Rescale Process Signals
- One Model to Interface Process Signals with Panel Meters, Recorders, Data Acquisition Cards, PLCs, DCS Systems, SCADA Systems

Specifications

Input Ranges

Consult factory for optional switch selectable ranges within I/O limits
 System voltages must not exceed socket voltage rating

Minimum Voltage: 0 to 1 VDC
 Maximum Voltage: 0 to 200 VDC
 Maximum Bipolar Voltage: ± 200 VDC

Input Impedance

Voltage: 1 M Ω minimum

LoopTracker

Variable brightness LEDs indicate input/output loop level and status

Output Ranges

	Minimum	Maximum	Load Factor
Voltage:	0-1 VDC	0-10 VDC	
Bipolar Voltage:	± 1 VDC	± 10 VDC	
Current (20 V compliance):	0-2 mADC	0-20 mADC	1000 Ω at 20 mA

Output Zero and Span

Multiturn potentiometers to compensate for load and lead variations
 $\pm 15\%$ of span adjustment range typical

Functional Test Button

Sets output to test level when pressed
 Potentiometer factory set to approximately 50% of span
 Adjustable 0-100% of span

Output Linearity

Better than $\pm 0.1\%$ of span

Output Ripple and Noise

Less than 10 mV_{RMS}

Response Time

Standard: 100 milliseconds typical
 High speed: 30 milliseconds typical with DF option

Isolation

2000 V_{RMS} minimum
 Full isolation: power to input, power to output, input to output

Ambient Temperature Range

-10°C to +60°C operating

Temperature Stability

Better than $\pm 0.02\%$ of span per °C

Power

Standard: 115 VAC $\pm 10\%$, 50/60 Hz, 2.5 W max.
A230 option: 230 VAC $\pm 10\%$, 50/60 Hz, 2.5 W max.
D option: 9-30 VDC, 2.5 W typical



DC Input

Description and Features

The **API 4380 G HV3** accepts a DC voltage input and provides an optically isolated DC voltage or current output that is linearly related to the input. This module is unique because it is field rangeable for voltage inputs to ± 200 VDC. Typical applications include signal isolation and signal conversion.

The optical isolation between input and output makes this module useful for ground loop elimination, common mode signal rejection or noise pickup reduction. The module power supply is isolated, resulting in full 3-way (input, output, power) isolation.

The **API 4380 G HV3** can be field-configured via external rotary and slide switches. Most common ranges are built-in, and can be selected from the table on the module, however virtually unlimited combinations are possible. Consult the factory for assistance with special ranges.

API exclusive features include two **LoopTracker** LEDs and a **Functional Test Pushbutton**. The LoopTracker LEDs (Green for input, Red for output) vary in intensity with changes in the process input and output signals. Monitoring the state of these LEDs can provide a quick visual picture of your process loop at all times.

The functional test pushbutton provides a fixed output (independent of the input) when held depressed. The test output level can be field-adjusted via a multiturn potentiometer. Both the LoopTracker LEDs and functional test pushbutton greatly aid in saving time during initial startup and/or troubleshooting.

The **API 4380 G HV3** plugs into an industry standard 8-pin octal socket sold separately. Sockets **API 008** and finger-safe **API 008 FS** allow either DIN rail or panel mounting.

Model Options

API 4380 G HV3 Field rangeable high voltage input DC to DC isolated transmitter, 115 VAC

Options—Add to end of model number

- A230** Powered by 230 VAC, 50/60 Hz
- D** Powered by 9-30 VDC
- DF** Fast response, 1 millisecond nominal response time
- U** Conformal coating for moisture resistance

Accessories—Order as separate line item

- API 008** 8-pin socket
- API 008 FS** 8-pin finger-safe socket
- API TK36** DIN rail, 35 mm W x 39" L, aluminum



API 4380 GHV3 Installation and Setup

ELECTRICAL CONNECTIONS

WARNING! All wiring must be performed by qualified personnel only. This module requires an industry-standard 8-pin socket. Order API 008 or finger-safe API 008 FS socket separately.

Power Input Terminals – The white label on the side of the API module will indicate the power requirements. AC power is connected to terminals 1 and 3. For DC powered modules, polarity MUST be observed. Positive (+) is wired to terminal 1 and negative (-) is wired to terminal 3.

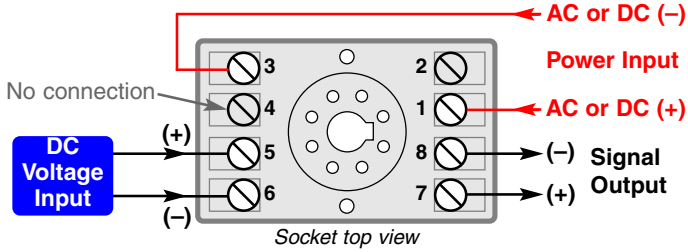

Connecting an input device which provides power to the input circuit

Signal Input – Polarity must be observed when connecting the signal input. The positive connection (+) is applied to terminal 5 and the negative (-) is applied to terminal 6.

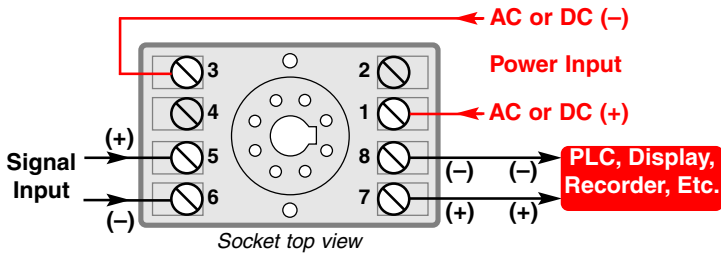

API 4380 G HV3 typical output wiring

Signal Output Terminals – Polarity must be observed when connecting the signal output to the load. The positive connection (+) is connected to terminal 7 and the negative (-) is connected to terminal 8.

RANGE SELECTION

Two slide switches and three rotary switches located on the side of the module are used to select input and output ranges. Most popular ranges are listed on the module label and the table at right. See www.api-usa.com or contact factory for special ranges.

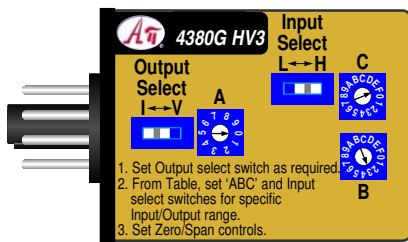

1. Shut off or disconnect power to the module input and the module power.
2. Unplug the module from its socket. Do not change ranges while the module is powered.
3. Locate the switch combination for your desired input and output ranges from the table.
4. Set the **OUTPUT SELECT** slide switch to current (I) or voltage (V) depending on output type.
5. Set the three rotary switches **A**, **B**, and **C** to the values found in the table.
6. Set the **INPUT SELECT** slide switch to **L** or **H** depending on table value.
7. The Zero, Span and Test Range potentiometers can now be adjusted for the desired output range.

Depending on the rotary switch settings, the input is filtered, either amplified or attenuated as required, then passed through an optical isolation circuit to the output stage.

CALIBRATION

Input and output ranges are pre-configured at the factory as specified on your order. Top-mounted, Zero and Span potentiometers can be used should fine-tuning be necessary. Custom ranges may require factory modification.

1. Apply power to the module and allow a minimum 20 minute warm up time.
2. Using an accurate calibration source, provide an input to the module equal to the minimum input required for the application.
3. Using an accurate measurement device for the output, adjust the Zero potentiometer for the exact minimum output desired. The Zero control should only be adjusted when the input signal is at its minimum. This will produce the corresponding minimum output signal. Example: For 4-20 mA output signal, the Zero control will provide adjustment for the 4 mA or low end of the signal.
4. Set the input at maximum, and then adjust the Span pot for the exact maximum output desired. The Span control should only be adjusted when the input signal is at its maximum. This will produce the corresponding maximum output signal. Example: For 4-20 mA output signal, the Span control will provide adjustment for the 20 mA or high end of the signal.
5. Repeat adjustments for maximum accuracy.

TEST BUTTON & TEST RANGE

The Test pushbutton may be set to provide the desired output when depressed. This will drive the device on the output side of the loop (a panel meter, chart recorder, etc.) with a known good signal that can be used as a system diagnostic aid during initial start-up or during troubleshooting. It can be adjusted to vary the output signal from 0 to 100% of the calibrated output range. When released, the output will return to normal.

Turn the multi-turn Test Range potentiometer while holding the Test Switch depressed until the desired output test level is reached.

Example: If you are isolating a 4-20 mA current loop, when the pushbutton is held depressed, the output from the module will be a constant signal between 4 and 20 mA depending on the setting of the Test Range adjustment pot.

OPERATION

GREEN LoopTracker® Input LED – Provides a visual indication that a signal is being sensed by the input circuitry of the module. It also indicates the input signal strength by changing in intensity as the process changes from minimum to maximum. If the LED fails to illuminate, or fails to change in intensity as the process changes, this may indicate a problem with module power or signal input wiring.

RED LoopTracker output LED – Provides a visual indication that the output signal is functioning. It becomes brighter as the input and the corresponding output change from minimum to maximum. For current outputs, the RED LED will only light if the output loop current path is complete. For either current or voltage outputs, failure to illuminate or a failure to change in intensity as the process changes may indicate a problem with the module power or signal output wiring.

		OUTPUT RANGES																		
		0-1 V		0-2 V		0-5 V		1-5 V		0-10 V		±5 V		±10 V		4-20 mA		0-20 mA		
Switches		ABC	I/O	ABC	I/O	ABC	I/O	ABC	I/O	ABC	I/O	ABC	I/O	ABC	I/O	ABC	I/O	ABC	I/O	
		I N P U T	0-20 V	011 H V	111 H V	311 H V	213 H V	611 H V	811 H V	911 H V	513 H I	611 H I	0-30 V	021 L V	121 L V	321 L V	223 L V	621 L V	821 L V	921 L V
0-40 V	021 H V		121 H V	321 H V	223 H V	621 H V	821 H V	921 H V	523 H I	621 H I	0-50 V	041 H V	141 H V	341 H V	243 H V	641 H V	841 H V	941 H V	543 H I	641 H I
0-60 V	031 L V		131 L V	331 L V	233 L V	631 L V	831 L V	931 L V	533 L I	631 L I	0-80 V	031 H V	131 H V	331 H V	233 H V	631 H V	831 H V	931 H V	533 H I	631 H I
20-100 V	03F H V		13F H V	33F H V	231 H V	63F H V	83F H V	93F H V	531 H I	63F H I	0-100 V	051 H V	151 H V	351 H V	253 H V	651 H V	851 H V	951 H V	553 H I	651 H I
0-150 V	061 L V		161 L V	361 L V	263 L V	661 L V	861 L V	961 L V	563 L I	661 L I	0-200 V	061 H V	161 H V	361 H V	263 H V	661 H V	861 H V	961 H V	563 H I	661 H I
±75 V	064 L V		164 L V	364 L V	266 L V	664 L V	864 L V	964 L V	566 L I	664 L I	±100 V	064 H V	164 H V	364 H V	266 H V	664 H V	864 H V	964 H V	566 H I	664 H I
±150 V	074 L V		174 L V	374 L V	276 L V	674 L V	874 L V	974 L V	576 L I	674 L I	±200 V	074 H V	174 H V	374 H V	276 H V	674 H V	874 H V	974 H V	576 H I	674 H I



RANGE SELECTION

Two slide switches and three rotary switches located on the side of the module are used to select input and output ranges. Most popular ranges are listed on the module label and the table below. See www.api-usa.com or contact factory for special ranges.

1. Shut off or disconnect power to the module input and the module power.
2. Unplug the module from its socket. Do not change ranges while the module is powered.
3. Locate the switch combination for your desired input and output ranges from the table.
4. Set the **OUTPUT SELECT** slide switch to current (I) or voltage (V) depending on output type.
5. Set the three rotary switches **A**, **B**, and **C** to the values found in the table.
6. Set the **INPUT SELECT** slide switch to **L** or **H** depending on table value.
7. The Zero, Span and Test Range potentiometers can now be adjusted for the desired output range.

Depending on the rotary switch settings, the input is filtered, either amplified or attenuated as required, then passed through an optical isolation circuit to the output stage.

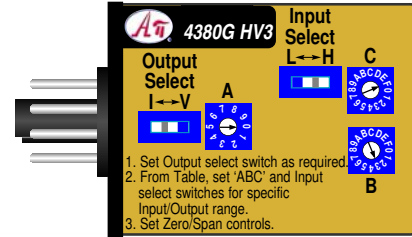

API 4380 G HV3 OUTPUT RANGES

Switches	0-1 V	0-2 V	0-4 V	0-5 V	1-5 V	0-8 V	2-10 V	0-10 V	±5 V	±10 V	0-2 mA	0-10 mA	2-10 mA	0-16 mA	4-20 mA	0-20 mA	
	ABC IO	ABC IO	ABC IO	ABC IO	ABC IO	ABC IO	ABC IO	ABC IO	ABC IO	ABC IO	ABC IO	ABC IO	ABC IO	ABC IO	ABC IO	ABC IO	
INPUT RANGES	0-1 V	081 H V	181 H V	281 H V	381 H V	283 H V	581 H V	583 H V	681 H V	881 H V	981 H V	081 H I	381 H I	283 H I	581 H I	583 H I	681 H I
	0-2 V	091 H V	191 H V	291 H V	391 H V	293 H V	591 H V	593 H V	691 H V	891 H V	991 H V	091 H I	391 H I	293 H I	591 H I	593 H I	691 H I
	0-3 V	0A1 L V	1A1 L V	2A1 L V	3A1 L V	2A3 L V	5A1 L V	5A3 L V	6A1 L V	8A1 L V	9A1 L V	0A1 L I	3A1 L I	2A3 L I	5A1 L I	5A3 L I	6A1 L I
	0-4 V	0A1 H V	1A1 H V	2A1 H V	3A1 H V	2A3 H V	5A1 H V	5A3 H V	6A1 H V	8A1 H V	9A1 H V	0A1 H I	3A1 H I	2A3 H I	5A1 H I	5A3 H I	6A1 H I
	0-5 V	0C1 H V	1C1 H V	2C1 H V	3C1 H V	2C3 H V	5C1 H V	5C3 H V	6C1 H V	8C1 H V	9C1 H V	0C1 H I	3C1 H I	2C3 H I	5C1 H I	5C3 H I	6C1 H I
	0-8 V	0B1 H V	1B1 H V	2B1 H V	3B1 H V	2B3 H V	5B1 H V	5B3 H V	6B1 H V	8B1 H V	9B1 H V	0B1 H I	3B1 H I	2B3 H I	5B1 H I	5B3 H I	6B1 H I
	0-10 V	001 H V	101 H V	201 H V	301 H V	203 H V	501 H V	503 H V	601 H V	801 H V	901 H V	001 H I	301 H I	203 H I	501 H I	503 H I	601 H I
	0-15 V	011 L V	111 L V	211 L V	311 L V	213 L V	511 L V	513 L V	611 L V	811 L V	911 L V	011 L I	311 L I	213 L I	511 L I	513 L I	611 L I
	0-20 V	011 H V	111 H V	211 H V	311 H V	213 H V	511 H V	513 H V	611 H V	811 H V	911 H V	011 H I	311 H I	213 H I	511 H I	513 H I	611 H I
	0-30 V	021 L V	121 L V	221 L V	321 L V	223 L V	521 L V	523 L V	621 L V	821 L V	921 L V	021 L I	321 L I	223 L I	521 L I	523 L I	621 L I
	0-40 V	021 H V	121 H V	221 H V	321 H V	223 H V	521 H V	523 H V	621 H V	821 H V	921 H V	021 H I	321 H I	223 H I	521 H I	523 H I	621 H I
	0-50 V	041 H V	141 H V	241 H V	341 H V	243 H V	541 H V	543 H V	641 H V	841 H V	941 H V	041 H I	341 H I	243 H I	541 H I	543 H I	641 H I
	0-60 V	031 L V	131 L V	231 L V	331 L V	233 L V	531 L V	533 L V	631 L V	831 L V	931 L V	031 L I	331 L I	233 L I	531 L I	533 L I	631 L I
	0-75 V	051 L V	151 L V	251 L V	351 L V	253 L V	551 L V	553 L V	651 L V	851 L V	951 L V	051 L I	351 L I	253 L I	551 L I	553 L I	651 L I
	0-80 V	031 H V	131 H V	231 H V	331 H V	233 H V	531 H V	533 H V	631 H V	831 H V	931 H V	031 H I	331 H I	233 H I	531 H I	533 H I	631 H I
	20-100 V	03F H V	13F H V	23F H V	33F H V	231 H V	53F H V	531 H V	63F H V	83F H V	93F H V	03F H I	33F H I	231 H I	53F H I	531 H I	63F H I
	0-100 V	051 H V	151 H V	251 H V	351 H V	253 H V	551 H V	553 H V	651 H V	851 H V	951 H V	051 H I	351 H I	253 H I	551 H I	553 H I	651 H I
	0-150 V	061 L V	161 L V	261 L V	361 L V	263 L V	561 L V	563 L V	661 L V	861 L V	961 L V	061 L I	361 L I	263 L I	561 L I	563 L I	661 L I
	0-200 V	061 H V	161 H V	261 H V	361 H V	263 H V	561 H V	563 H V	661 H V	861 H V	961 H V	061 H I	361 H I	263 H I	561 H I	563 H I	661 H I
	±75 V	064 L V	164 L V	264 L V	364 L V	266 L V	564 L V	566 L V	664 L V	864 L V	964 L V	064 L I	364 L I	266 L I	564 L I	566 L I	664 L I
±100 V	064 H V	164 H V	264 H V	364 H V	266 H V	564 H V	566 H V	664 H V	864 H V	964 H V	064 H I	364 H I	266 H I	564 H I	566 H I	664 H I	
±150 V	074 L V	174 L V	274 L V	374 L V	276 L V	574 L V	576 L V	674 L V	874 L V	974 L V	074 L I	374 L I	276 L I	574 L I	576 L I	674 L I	
±200 V	074 H V	174 H V	274 H V	374 H V	276 H V	574 H V	576 H V	674 H V	874 H V	974 H V	074 H I	374 H I	276 H I	574 H I	576 H I	674 H I	

API maintains a constant effort to upgrade and improve its products. Specifications are subject to change without notice. Consult factory for your specific requirements.

For Your Local Area Representative See www.api-usa.com

Frequently Asked Questions

Do you recommend placing a fuse at the power input (115 VAC) for protection?

It is not required, but if desired, a ½ Amp Fast Blow fuse can be used for each module.

We are using many different types of your signal conditioners and wish to protect the inputs and outputs from short circuits and over voltage. How can we achieve this?

Applying a short circuit to any of the signal input terminals will not affect the modules. Exposing the signal input to high voltage will damage the unit but using a zener diode, due to its resistance value, will cause the input range to need recalibrating. Try a Varistor or TransZorb®. Do NOT under any circumstances short circuit the signal output, the unit can be damaged.

For modules with a 4-20 mA output signal, what are the minimum and maximum output load resistance?

For the units with a 20 V compliance, the output range is 10 to 1000 ohms.

For the units with a 12 V compliance, the output range is 10 to 600 ohms.

For the DC output models, what are the output impedances in the voltage and current mode?

The DC outputs are FET driven and are active outputs that change depending on the mode and range.

CURRENT Mode

DC output with 12 V Compliance

DC output with 20 V Compliance

VOLTAGE Mode

less than 600 ohms

less than 1000 ohms

greater than 1000 ohms

greater than 1000 ohms

For your DC Input modules in the current mode, the input impedance rating is 50 ohms. For troubleshooting purposes, is that value the same with and without power applied to the module?

Yes.

TransZorb—Reg TM General Semiconductor

What is a Ground Loop?

In a process control loop, a ground loop circuit can develop when each device's ground is tied to a different earth potential thereby allowing current to flow between the grounds by way of the process loop (Figure 1).

Ground loops cause problems by adding or subtracting current or voltage from the process loop. This addition and/or subtraction causes the receiving device to be unable to differentiate between the wanted and unwanted signals and thus can't accurately reflect actual process signals.

The probability of multiple grounds and ground loops being established is especially high when new programmable logic controllers (PLCs) or distributed control systems (DCSs) are installed. With so many conditions within a facility referenced to ground, the likelihood of establishing more than one ground point is great. Thus, if an instrumentation system seems to be acting strangely or erratically, and the problem seems to point toward ground loops, the chore of eliminating all unintended ground connections becomes overwhelming.

Keep in mind that eliminating ground loops just isn't feasible for some instruments, such as thermocouples and some analyzers, because they require a ground to obtain accurate measurements. In addition, some instruments must be grounded to ensure personnel safety. When ground loops can't be eliminated, the solution lies in the use of signal isolators. These devices break the galvanic path (DC continuity) between all grounds while allowing the analog signal to continue throughout the loop. An isolator also can eliminate the electrical noise of AC continuity (common mode voltage).

Signal isolators can use numerous techniques to achieve their function but the best signal isolators usually employ optical isolators (Figure 2). Regardless of the isolation method used, an isolator must provide input, output, and power isolation. If this three-way isolation is not provided, then an additional ground loop can develop between the isolator's power supply and the process input and/or output signal.

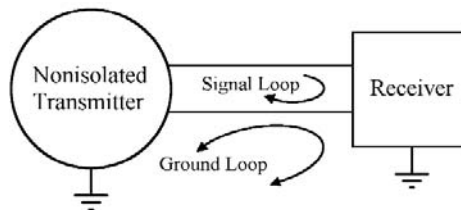

Figure 1. Ground loops may develop with non-isolated transmitters and receivers, resulting in inaccuracy and unreliability.

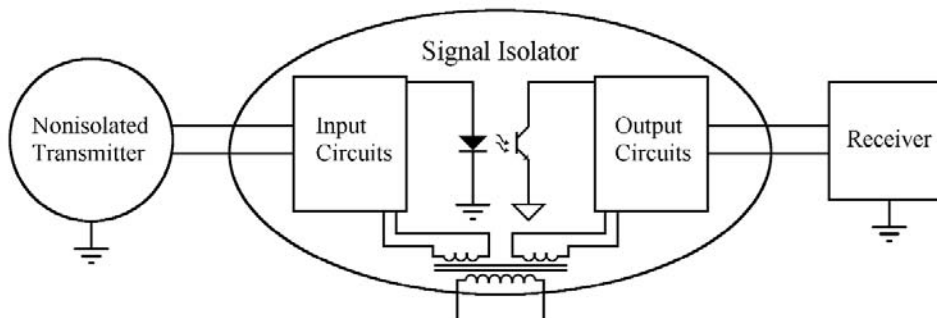

Figure 2. A signal isolator in the process loop blocks ground current to restore signal accuracy and reliability.